

USER'S MANUAL

Revision: 4



HEC-HMI-C215x-E-R HEC-HMI-C415x-E-R

For Models: HEC-HMI-C2150-E-R
 HEC-HMI-C2151-E-R
 HEC-HMI-C2152-E-R
 HEC-HMI-C4150-E-R
 HEC-HMI-C4151-E-R
 HEC-HMI-C4152-E-R

Manual Contents

Getting Started

How to Use this Manual	4
Configuring the HEC-HMI Target in EZ LADDER Toolkit	5
Loading the HEC-HMI Kernel	7

HEC-HMI Basics

Getting to Know the HEC-HMI.....	10
HEC-HMI Assembly / Disassembly.....	12
Wiring to the HEC-HMI.....	13
Mounting the HEC-HMI.....	15
HEC-HMI Specifications	16

HEC-HMI Power

Input Power	17
Input Power Connections.....	17
Input Power Monitor.....	18

Communication Ports

Programming Port	19
Modbus, General Purpose Serial Port	20
OptiCAN Port / J1939 Port.....	22

User Interface

HMI Display	25
Display Contrast Control.....	25
Display Backlight Control.....	25
Programmable LEDs	25
Status LEDs	26
Programmable Buttons	26
Display Heater Control	27
Programmable Horn.....	27

Memory

Memory Overview	28
RAM Memory	28
FLASH Memory.....	28
Retentive Memory	29
EEPROM Memory.....	29

Digital I/O

Digital Inputs Overview	30
Dedicated Inputs	30
Multi-Use Inputs as Digital Inputs	31
Multi-Use Inputs as High Speed Counter Inputs	33
Digital Outputs Overview	35
Solid-State Digital Outputs as General Purpose Outputs	35
Solid-State Digital Outputs as PWM	38
Relay Outputs	40

Analog I/O

Analog Inputs Overview	41
Real World Analog Inputs	41
Solid-State Output Current Feedback	42

Expansion Option 1

Getting to Know Expansion Option 1	44
Analog Input	45
Digital Outputs Overview	46
Solid-State Digital Outputs as General Purpose Outputs	46
Solid-State Digital Outputs as PWM	48
Quadrature Counter	50

Expansion Option 2

Getting to Know Expansion Option 2	54
Analog Input	55
Digital Outputs Overview	56
Solid-State Digital Outputs as General Purpose Outputs	56
Solid-State Digital Outputs as PWM	58
Quadrature Counter	60
DAC Outputs	63
Thermocouple Inputs	63

WARNING!!

The HEC-HMI-C215x/C415x-E-R as with other programmable controllers must not be used alone in applications which could be hazardous to personnel in the event of failure of this device. Precautions must be taken by the user to provide mechanical and/or electrical safeguards external to this device. This device is **NOT APPROVED** for domestic or human medical use.

Getting Started

This section explains how to read this manual and understand the symbols and information that it contains.

To begin using your HEC HMI, you will need to follow these steps:

- Install EZ LADDER Toolkit if not already installed (not included).
- Configure the HEC HMI in the EZ LADDER Toolkit Project Settings.
- Connect the Input Power and Programming Port.
- Write a ladder diagram program.
- Install the HEC-HMI's Kernel.
- Download and run the program on the HEC HMI.

Refer to the appropriate sections of this manual for details on the above items.

How to Use this Manual

In this manual, the following conventions are used to distinguish elements of text:

BOLD	Denotes labeling, commands, and literal portions of syntax that must appear exactly as shown.
<i>italic</i>	Used for variables and placeholders that represent the type of text to be entered by the user.
SMALL CAPS	Used to show key sequences or actual buttons, such as OK, where the user clicks the OK button.

In addition, the following symbols appear periodically in the left margin to call the readers attention to specific details in the text:



Warns the reader of a potential danger or hazard associated with certain actions.



Appears when the text contains a tip that is especially useful.



Indicates the text contains information to which the reader should pay particularly close attention.

All Specifications and Information Subject to Change without Notice

Configuring the HEC-HMI Target in EZ LADDER Toolkit

Before you can program and use the HEC-HMI, it must be configured as a target within the EZ LADDER Toolkit. For help with installing or using EZ LADDER, please refer to the EZ LADDER User's Manual.

1. In EZ LADDER, from the File Menu at the top, click **PROJECT** then **SETTINGS**. This will open the Project Settings Window. Select **HEC-HMI** as the target from the choices. Refer to Figure 1.

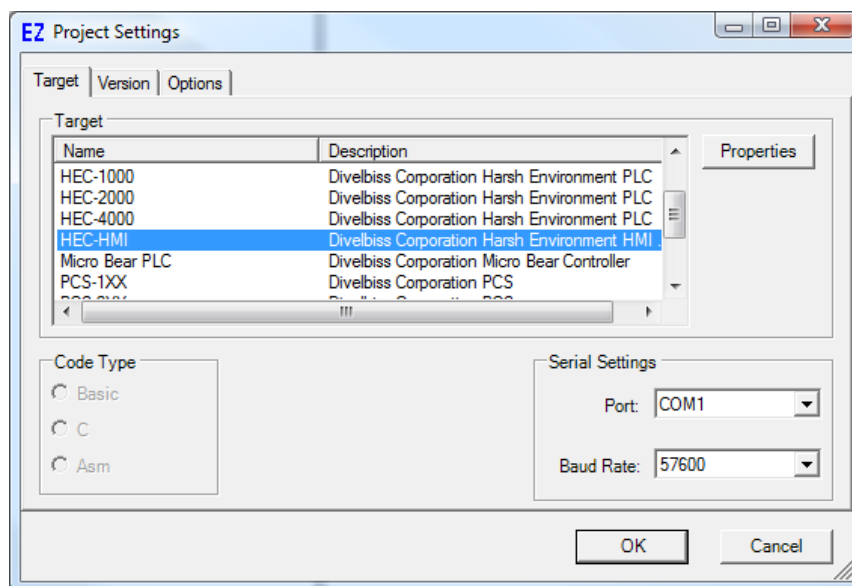

Figure 1 - Project Settings Window

2. Click the **PROPERTIES** button. A new window will open. Select the **HEC-HMI** base Model number of the HEC-HMI from the drop-down menu (HEC-HMI-C2150, etc). If your model includes an expansion option, it is determined by the last number found in the model number. For example, HEC-HMI-C2152 would be a base model of HEC-HMI-C2150 with the #2 expansion option installed.

If an expansion option is installed, select it from the buttons located in the *Expansion Option* section. Refer to Figure 2. When the proper model and option have been selected, click **OK**. This will close the HEC-HMI Properties Window, saving the **HEC-HMI** as the target for this ladder diagram project.

3. Click **OK** to close the Project Settings Window.

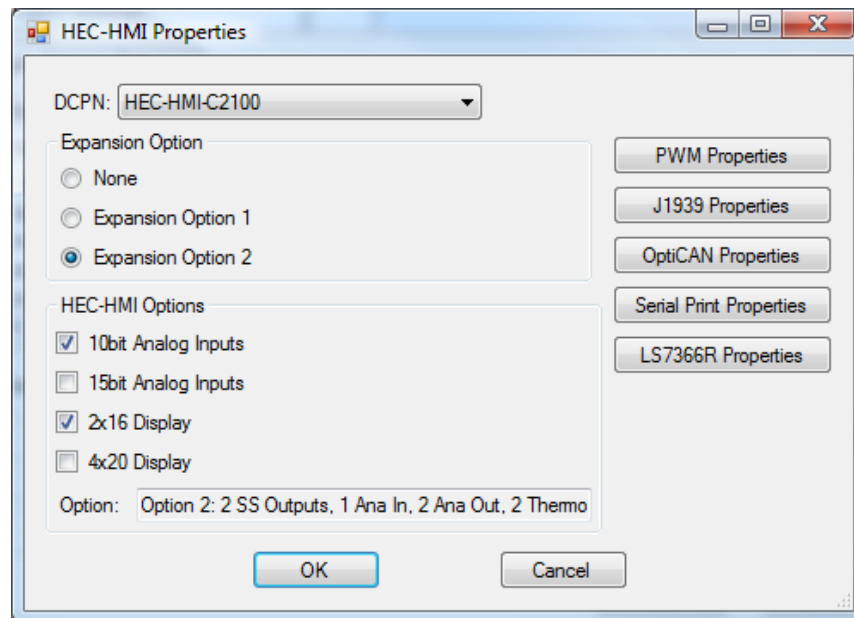





Figure 2 - HEC-HMI Properties Window

Loading the HEC-HMI Kernel

THE HEC-HMI WILL NOT FUNCTION UNLESS KERNEL LOADING (This Step) IS COMPLETED.

The kernel is the firmware for the HMI/Controller and to provide greater flexibility and reliability, HEC-HMI shipments are factory shipped **without** a kernel installed. If this is a new unit from the factory, it will be necessary to load the kernel before a ladder program can be downloaded. If the kernel is already loaded, this step is not required. To upgrade a kernel, see the EZ LADDER User's Manual.

To install the HEC-HMI's kernel:

1. Verify the target has been configured (see *Configuring the HEC-HMI Target in EZ LADDER Toolkit*).
2. Connect the Programming cable(s) from the computer to the HEC-HMI. See *Programming Port* in the *HEC-HMI COMPORTs* section. Wiring to the Programming Port's terminal blocks may be required.
3. Create a small one-rung program with a normally open (direct contact) and an output tied together. You may also open a pre-existing program for the HEC. EZ LADDER version 1.0.4.4 and later includes a sub-directory (...EZ LADDER\Kernel Install Start Programs\) which has starter programs for each target to load the kernel. Choose **GetStarted_HEC-HMI-C2150.dld** or **GetStarted_HEC-HMI-C4150.dld**
4. Click the  button to compile the program. The HEC-HMI will only accept compiled EZ LADDER Toolkit programs.
5. Click the  button to change EZ LADDER Toolkit from *Edit Mode* to *Monitor Mode*. Monitor Mode is required to communicate, download and monitor programs.
6. Click the  button to connect to the HEC-HMI. A dialog will appear automatically when no kernel is loaded. If this dialog does not appear, click **PROJECT** then **BOOTLOADER**. Refer to Figure 3.

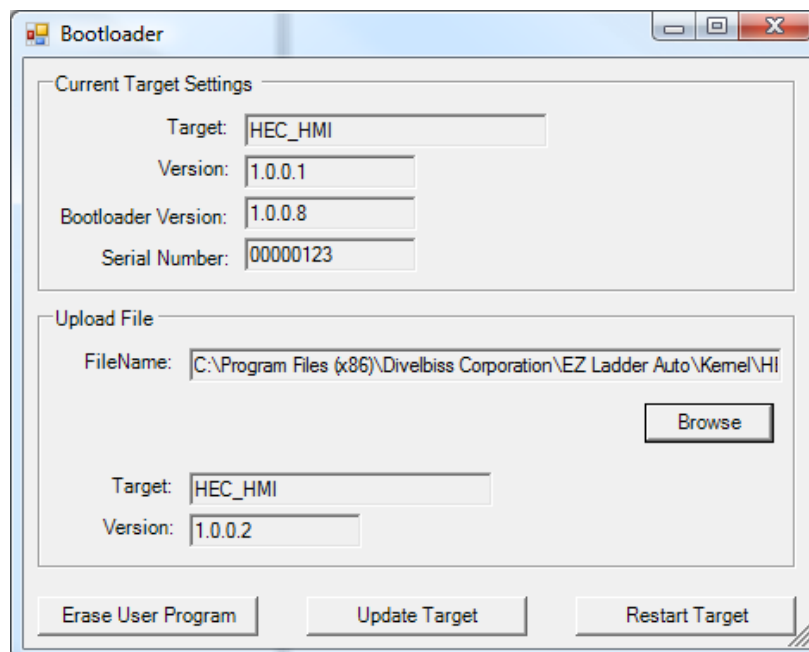

Figure 3 - Bootloader Window

7. Click the **BROWSE** button and select the target's kernel (by partnumber) located by default at C:\Program Files\EZ Ladder\Kernel\

The following are kernel names and descriptions:

<u>File Name</u>	<u>Description</u>	<u>To be Used on (Partnumber)</u>
HEC_HMI.dat	Kernel for HEC-HMI	HEC-HMI-C2150-E-R, HEC-HMI-C2151-E-R, HEC-HMI-C2152-E-R HEC-HMI-C4150-E-R, HEC-HMI-C4151-E-R, HEC-HMI-C4152-E-R

8. Click the **OPEN** button to finish the kernel selection. Make sure the correct kernel is chosen.

9. Click the **UPDATE TARGET** button to install the kernel.

10. A dialog box will appear to show the status of the kernel installation. This could take a several minutes to install.

11. When the status dialog window closes, the installation is complete. The HEC-HMI is ready to use and may be connected to and programs may be downloaded.



The HEC-HMI Serial Number is factory set and cannot be changed.

HEC-HMI Basics

This section provides you an overview of the HEC-HMI basics. Some of the basics that are covered are:

- Front Panel Features
- Wire Entry
- Assembly / Disassembly
- Internal Connections and Options

Getting to Know the HEC-HMI

The HEC-HMI-C215x/C415x-E-R is a powerful HMI and Programmable Logic Controller combined in one package, designed to communicate with other devices using Divelbiss OptiCAN or Modbus. The HEC-HMI boasts either a larger font 2x16 or standard font 4x20 backlit LCD display, four navigation buttons (up, down, left, right), Enter and four programmable buttons and four programmable LED indicators that may be used to display warnings, view data or change set points.

The HEC-HMI is housed in a rugged, plastic enclosure and can operate from -40°C to +80° C (using the internal display heater), making it a valuable tool in harsh environments where temperature extremes are encountered.

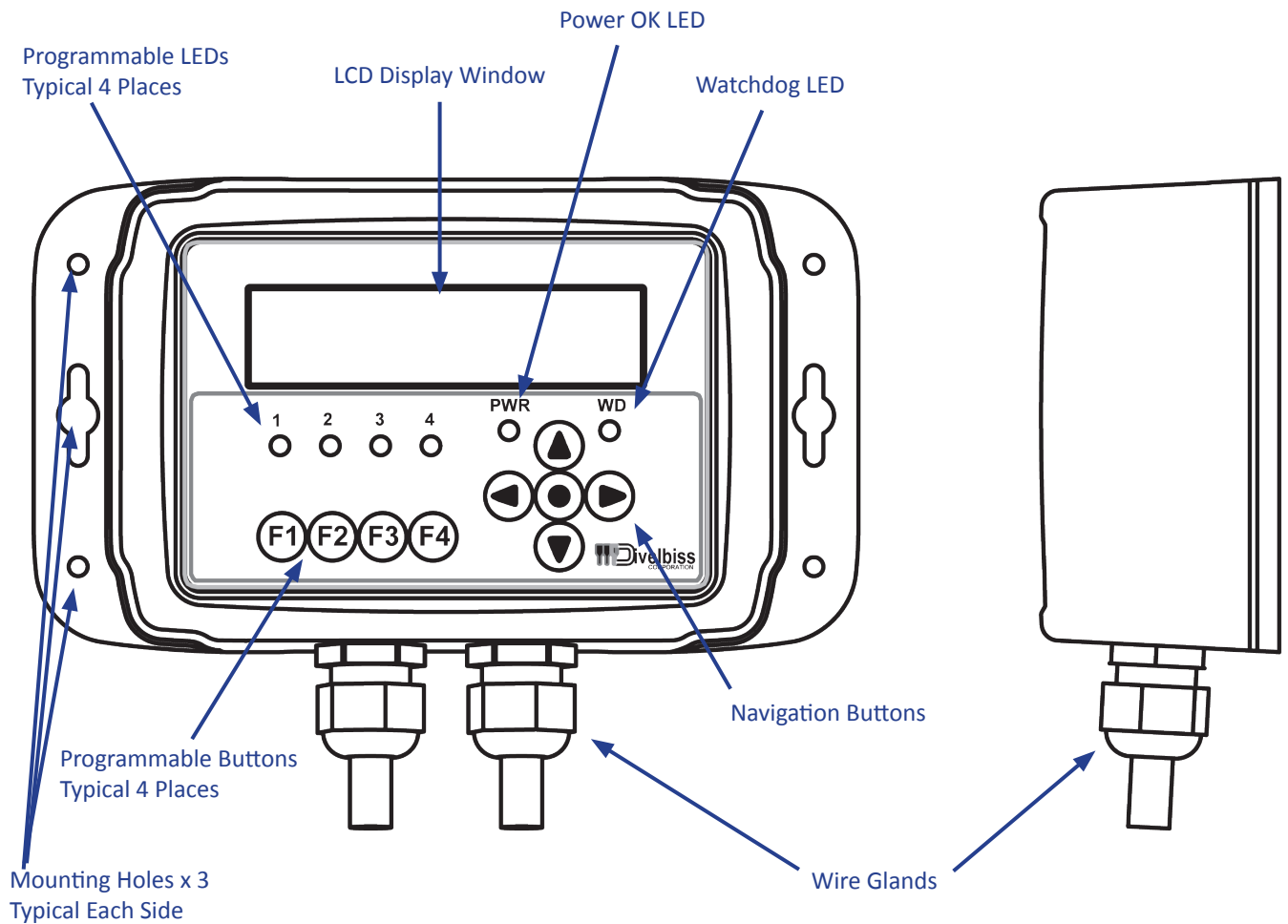

Figure 4 - External Features

The HEC-HMI-C215x/C415x supports many options and features. Many of the HEC-HMI features are selectable and must be configured by setting switch positions or jumpers internally in the HEC-HMI. To gain access to the internal connections and features, please see the HEC-HMI Assembly / Disassembly part of this manual section.

The following will get you familiar with the internal design of the HEC-HMI.

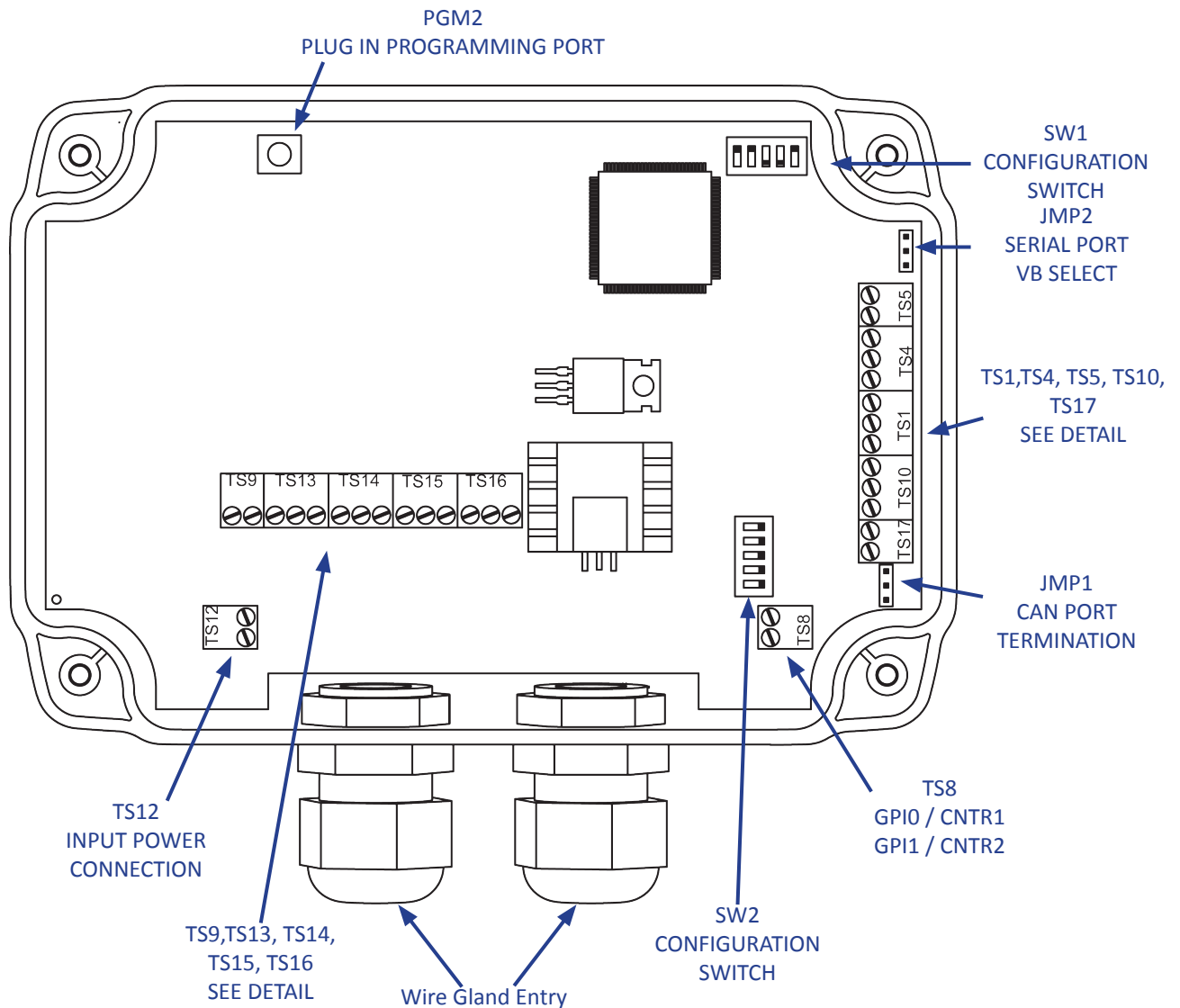

Figure 5 - Internal Features

The following diagram provides details for all the HEC-HMI-C215x/415x-E-R connections for Power, Communications and I/O. In addition, it also illustrates all the field configuration jumpers and switches with a label of each possible configuration. Each jumper and switch setting is covered in more detail in other sections of this manual.

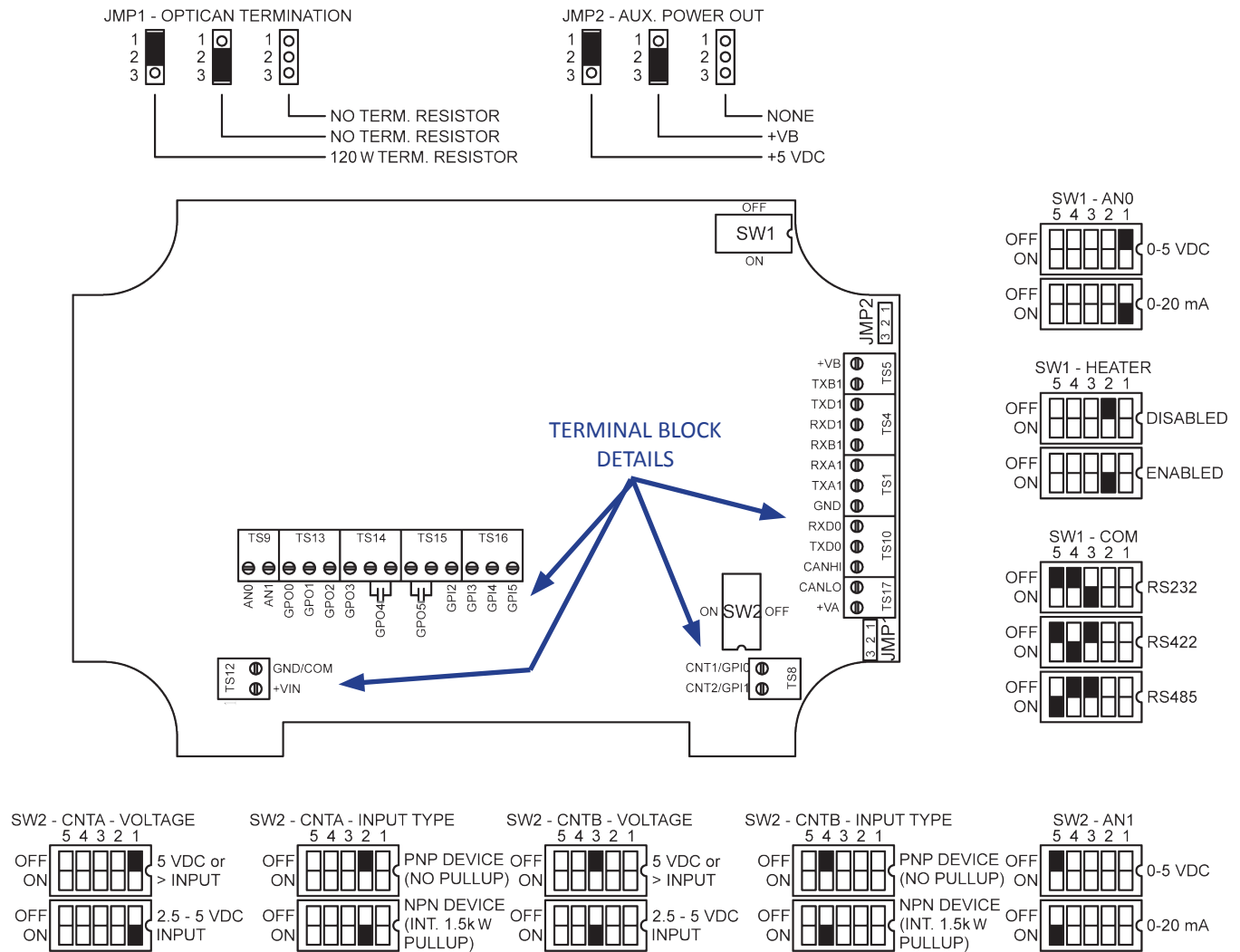

Figure 6 - Field Selectable Options

HEC-HMI Assembly / Disassembly

All configuration jumpers and terminal blocks are located inside the HEC-HMI enclosure. To configure the unit or to wire the unit, you must first gain access to the rear of the unit. If mounted to a surface, first un-mount the HEC-HMI to gain access to the rear (back side) of the unit. Removing the four screws as shown will allow the back of the unit's enclosure to be removed.

After configuration and wiring is complete, re-assemble the unit in reverse order. Align rear cover, install and tighten four screws as shown. If the unit was un-mounted, re-mount the unit to the original location.

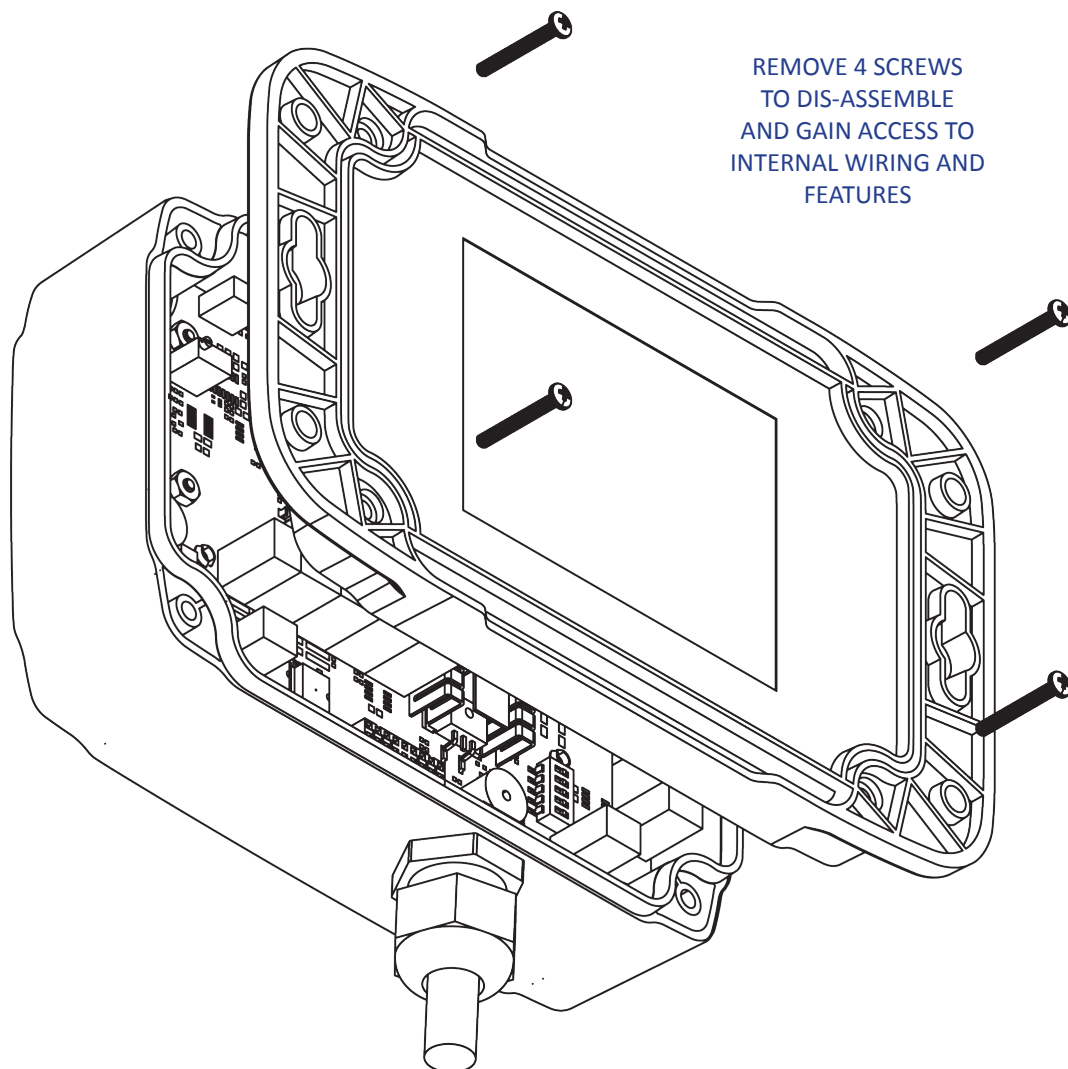

Figure 7 - Assembly / Disassembly

Wiring to the HEC-HMI

Before the HEC-HMI can be wired, it must be dis-assembled first, see the *HEC-HMI Assembly / Disassembly* of this manual.

All real-world connections on the HEC-HMI are terminal blocks. To allow wire entry into the HEC-HMI enclosure, use the wire glands that are provided. There will be one or two glands factory installed, based on the actual model number of the HEC-HMI. HEC-HMI Controllers are shipped with two glands installed, while HEC-HMI without controller is shipped with only one gland factory installed.



To loosen the glands and allow for wire installation, turn the locking nut counter-clockwise. As the nut is repeatedly turned, it will move outward, releasing the tension on the actual wire entry area. Feed the wires into the glands and route the wires internally in the HEC-HMI as shown. Refer to Figure 8.



All the provided terminal contact blocks will accept wire from 16 AWG to 26 AWG. For best results, use the size and type of wire appropriate for the function such as the minimum wire size necessary for the I/O or high quality shielded wire for analog inputs to promote noise immunity.

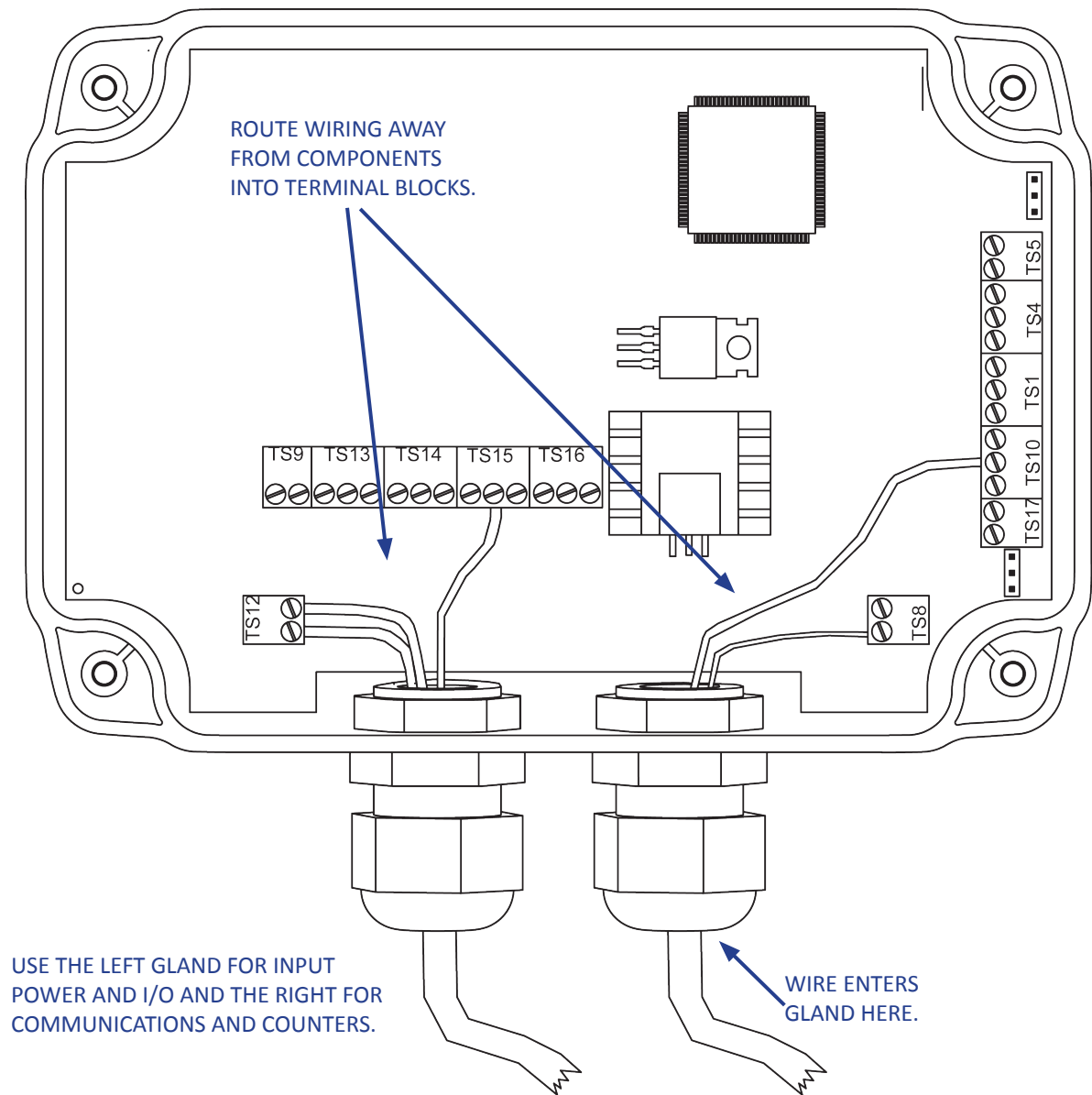

Figure 8 - Typical Internal Wire Routing

Mounting the HEC-HMI

The HEC-HMI is designed to directly mount to any relatively small flat surface or brackets. There are 6 different holes located in the back mounting flange. The HEC-HMI can be mounted using any combination of these mounting holes and appropriate screws or bolts as required. Refer to Figure 9.

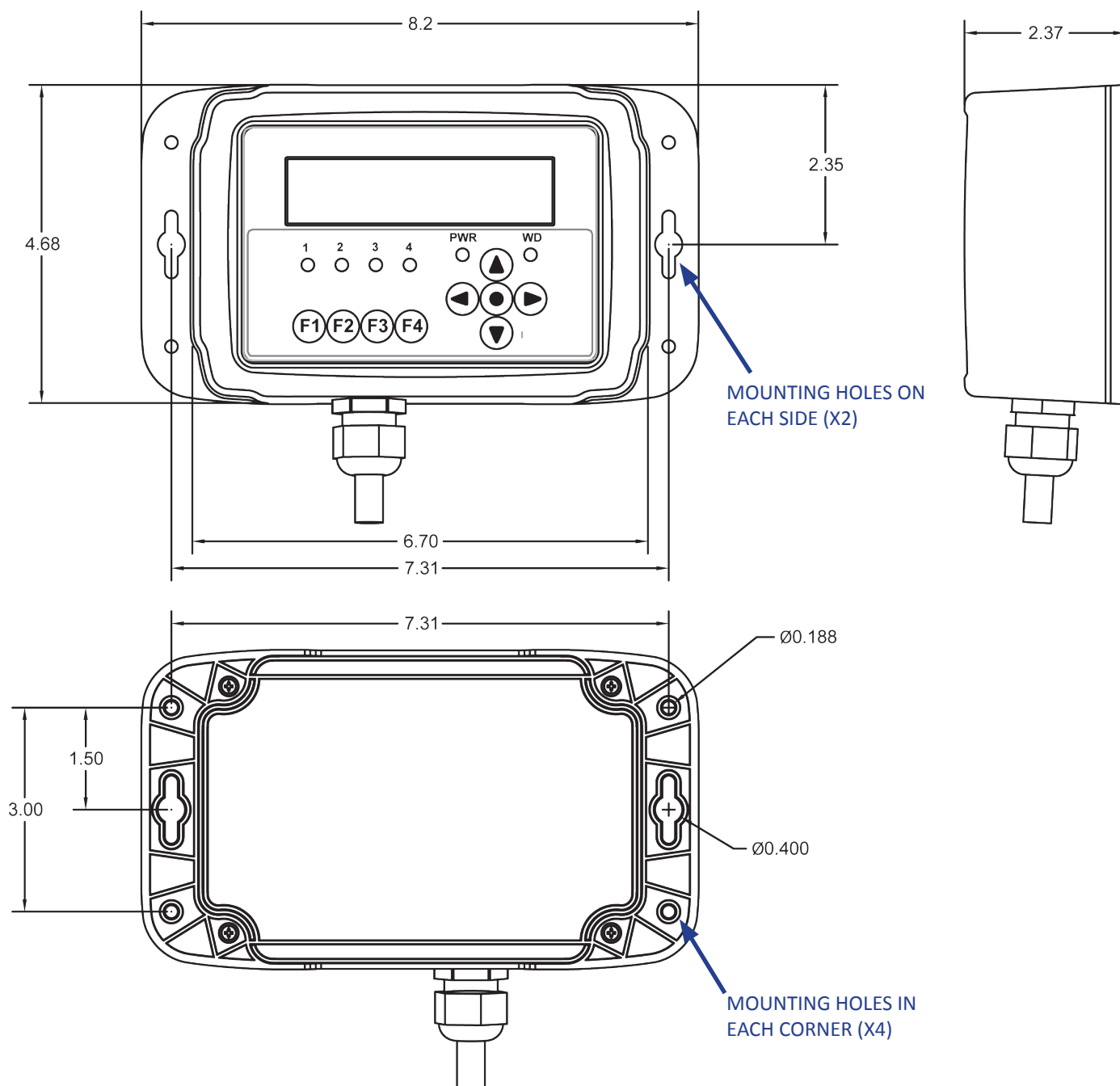

Figure 9 - Mounting & Dimensions

HEC-HMI Specifications

Processor	PLCHIP-M2-25620 (PLC on a Chip™)
User Program RAM	4K
User Program Flash	64K
Retentive Memory	100 Bytes
EEPROM Memory	2792 Bytes
Temperature Range	-40°C to 80°C
RoHS Status	RoHS Compliant
Environmental	Seal Enclosure, Rated NEMA 4X, IP66, UL94V-0
Mounting	Mounts to Panel using provided mounting holes.
Dimensions	5.8" Height x 8.2" Width x 2.4" Depth
Input Voltage	8-32 VDC
Input Current Max.	12.25ADC
Input Current Typical (no I/O or Heater)	110mADC @ 12VDC, 75mADC @ 24VDC
Display Type	Liquid Crystal Display (LCD)
Display Backlight	Yes, Controlled from Ladder Diagram
Display Heater	Yes, Can be enabled or disabled via Switch. Draws approximately 6mADC @ 12VDC and 3mADC @ 24VDC
Display Size	2 Rows with 16 Columns or 4 Rows with 20 Columns
Status LED Indicators	Qty 2, Power (PWR) and Watchdog (WD)
Programmable LEDs	Qty 4, Controlled from Ladder Diagram
Programmable Buttons	Qty 9, Up, Down, Left, Right, Center, F1, F2, F3 and F4. Programmable in Ladder Diagram as digital inputs (contacts).
Programming Port	Yes, Terminal Block Connection, RS232
Programming Language	Ladder Diagram using EZ LADDER Toolkit. Program Baud Rate = 57.6K
Multipurpose Serial Port	Yes, Terminal Block Connection, RS232, RS422 or RS485 - Switch Selectable.
CAN Port	Yes, Supports J1939 and Divalbiss OptiCAN
Supported Networks	J1939 and OptiCAN on CAN Port, Modbus Slave on Multipurpose Serial Port.
Wire Entry	Through Gland on bottom of HEC-HMI Enclosure
Digital Inputs	Qty 6, 4 Dedicated and 2 that may be used as High Speed Counter Inputs or Digital Inputs
Digital Input Rating	Sinking Inputs, 8-32VDC, Optically Isolated
Digital Input De-bounce	Standard for 4 Dedicated Inputs. 2 High Speed Counter Inputs De-bounce is Controlled in the Ladder Diagram.
High Speed Counter Inputs	Qty 2 (using 2 of the Digital Inputs). Max Frequency 250KHz.
High Speed Counter Input Type	User Switch Selectable, PNP or NPN (internal pull-up)
High Speed Counter Voltage	User Switch Selectable 2.5V - 5VDC or 5-32VDC
Digital Outputs	6 Total, 4 Solid-State and 2 Relay
Solid-State Digital Outputs	Sourcing, (Equal to Input Voltage). 4 Amp ^{SEE NOTE 1} Maximum per output pair. Can operate as On/Off Outputs or as Pulse Width Modulation (PWM) with frequency of 1.5 Hz to 1.0 KHz. Solid-State outputs have current feedback as analog inputs for closed loop control.
Relay Outputs:	Normally Open, Dry Contact. Rated 2 Amps Resistive.
Analog Inputs:	Qty 2 External, Qty 6 Internal.
External Analog Inputs	Rated 0-5VDC or 0-20mADC, User Switch Selectable.
Internal Analog Inputs	4 Current Feedback Channels for PWM Outputs, 1 Input Power Monitor Channel
Analog Input Resolution	15-bit

NOTE 1: 4ADC Total @ up to 50 °C Maximum per 2 Output Channels. Channels paired as GPO0 / GPO1 and GPO2 / GPO3. Total Current is sum of both paired output channels. See Output De-Rating Diagram (in Digital I/O Section) for maximum output current per output channel pair based on ambient temperature.

All Specifications Subject to Change Without Notice.

HEC-HMI Power

This section explains the connections and power requirements necessary to operate the HEC-HMI. In addition, this section covers additional information on power related features that may be used in the ladder diagram application software.

Input Power

The HEC-HMI will operate over a 8 to 32 VDC input voltage range. The current required will vary based on actual features used and environmental conditions. *Maximum current is worst case scenario with maximum current in use for each of the HEC-HMI's features including backlighting, heater, all PWM outputs at full load, etc.*

The input power terminal Block TS12 is rated for 10 Amps and can accept wire size from 26 AWG to 16 AWG. It is recommended if the total input current will exceed 8 Amps, wire the input power to a second point. This second point can be wired directly to TS17.

Maximum Current:	12.25ADC
Typical Current (Excluding I/O):	110mADC @ 12VDC, 90mADC @ 24VDC
Input Voltage Range:	8-32VDC

Input Power Connections

The input power is connected to the HEC-HMI via the provided terminal blocks as shown in Figure 10. The HEC-HMI back cover must be removed to connect the input power, see the HEC-HMI Basics section. Should the input current with I/O be greater than 8 Amps, a second +V input supply wire should be used. Refer to Outputs section for alternative Power Connections.

PRIMARY INPUT POWER SCHEMATIC

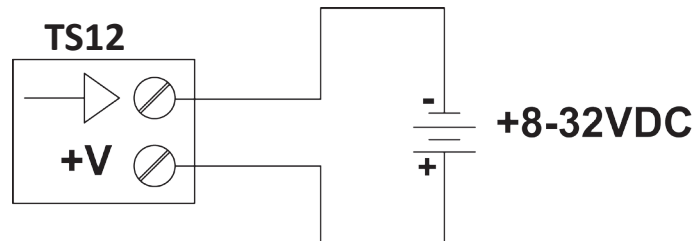

PRIMARY INPUT POWER WIRING

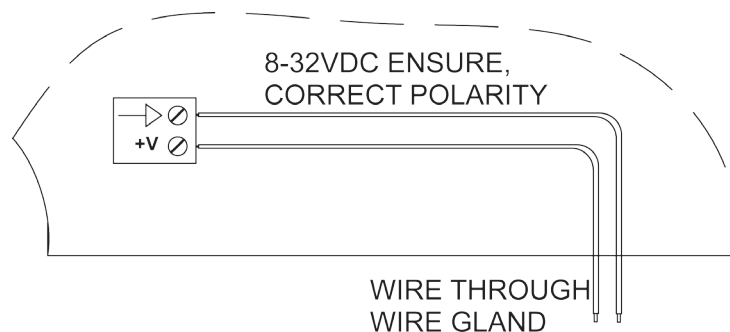

Figure 10 - Input Power Diagrams

Input Power Monitor



The HEC-HMI includes a voltage monitor that constantly reads the input voltage as an analog input. This analog input can be accessed in the ladder diagram program as an integer variable labeled **AN3**. This variable is automatically created when the HEC-HMI target is selected in the Project Settings Dialog.

As this is an integer value, it must be converted and scaled in the ladder diagram before it can be used as a process variable. The input should be scaled between 0-40 (0-40VDC). When scaling, use this equation.

$$InputV = (AN3 / AINScale) \times (MaxScale)$$

Where:

- InputV = Input Voltage (real variable) 0.0 to 40.0
- AN3 = Automatically created variable
- AINScale = 32767
- MaxScale = 40.0 (Real Variable to be created)
- AIN Resolution = 15-bit

Figure 11 is the same equation, as a EZ LADDER Toolkit ladder diagram program. Note, the Analog input is converted to a REAL for calculations. This program can be found in HEC-HMI Resource Zip file from our website (<http://www.divelbiss.com>).

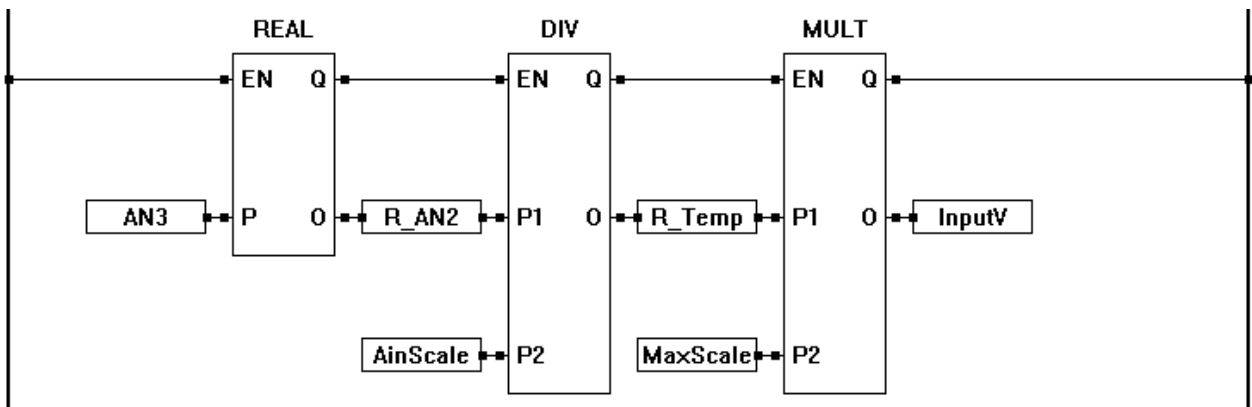

Figure 11 - Power Monitor Example Ladder Diagram

Communication Ports

This section explains all the communication options and ports for the HEC-HMI. Included will be descriptions of the types of ports, the typical circuit diagrams required and optional configurations that are available.

All HEC-HMI models are factory shipped with three communication ports; the Programming Port, the OptiCAN/J1939 Port and a General Purpose/Modbus Slave Port as RS232, RS422 or RS485 (Field Selectable). Details for each port are listed in this section.

Programming Port

The programming port, labeled **COM 0** is used to program the HEC-HMI target using the Divalbiss EZ LADDER Toolkit. This connection is an RS232 serial connection and is required to install the Kernel and to download programs to the HEC-HMI. This port is used for programming only and cannot be used for communication with any other software or device except EZ LADDER Toolkit.

EZ LADDER Toolkit uses the following settings to communicate to the HEC-HMI. Using any other setting will result in communications failures. These parameters are set within EZ LADDER Toolkit (some cannot be changed). You must select the correct COM Port to which the programming cable is connected to (on the PC). EZ LADDER Toolkit only lists available comports.

Baud Rate: 57600, **Parity:** None, **Data Bits:** 8, **Stop Bits:** 1

Connect your PC to the HEC-HMI via the provided terminal blocks as shown in Figure 12 or using a SI-PGM (sold separately) programming cable connected to PGM2 (See Figure 5 for PGM2 location and PGM2 may not be available on all models) . The HEC-HMI back must be removed to connect the input power and to program (wire). See the HEC-HMI Basics section. For models with PGM2, it is in parallel with the terminal blocks for COM0, providing the option of programming with an SI-PGM cable plugged-in or wiring the programming port to an external plug for programming without the need to un-mount or dis-assemble the HEC-HMI after original installation.

To reduce communication problems when using a USB to Serial Converter, please select a high quality manufacturer. A USB to Serial Converter that allow direct control over buffering is preferable. Divalbiss Corporation offers a model ideal for this purpose.

PROGRAM PORT CONNECTIONS SCHEMATIC

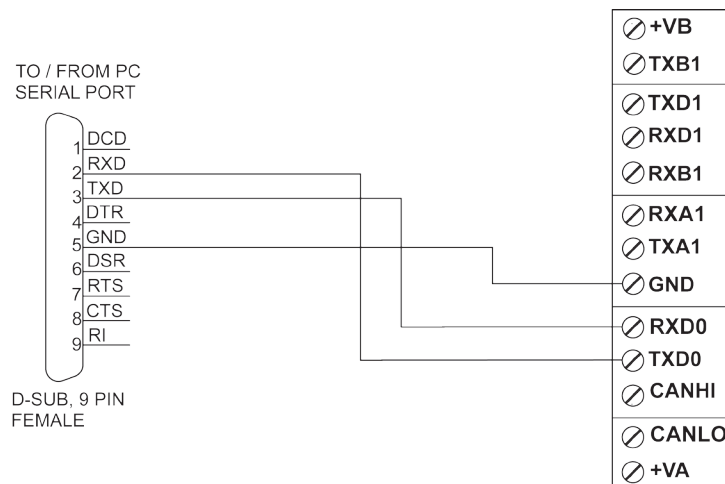

Figure 12 - Program Port Connections

Modbus, General Purpose Serial Port

The HEC-HMI provides a second serial port (COM 1) in addition to the programming Port. This port may be used as a general purpose serial port for printing to other devices using the SERIAL_PRINT function in EZ LADDER or it may be used on a Modbus network as a Modbus Slave.

COM 1 may be used as an RS232, RS422 or RS485. The mode of operation is dependent upon the wiring and the configuration of the COM 1 settings in the HEC-HMI using the configuration switch SW1. To use the COM 1 multipurpose serial port, connect to the COM 1 serial port as shown based on the type of configuration (RS232, RS422 or RS485), then configure the switch settings as shown Figure 13.

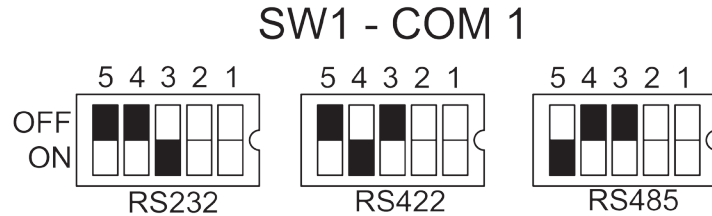

Figure 13 - COM 1 Options Switch Settings

Generally, communications between two devices is generally accomplished using RS232 for short distances or RS422 for longer distances or where additional electrical noise immunity is required due to the environment the device(s) are installed in or near. RS485 is generally used for applications where multiple drops (more than two devices) are required.

For the HEC-HMI, RS232 only requires 3 wires, RS422 requires 4 wires while RS485 is a two-wire system.

The EZ LADDER Toolkit COM 1 settings are set in the Project Settings dialog. The parameters are set under Serial Print when using the port to serially print to an external device or they are set under Modbus when using the port as a slave on a Modbus network.

Refer to the EZ LADDER Toolkit User Manual for details on configuring and using Modbus and Serial Print.

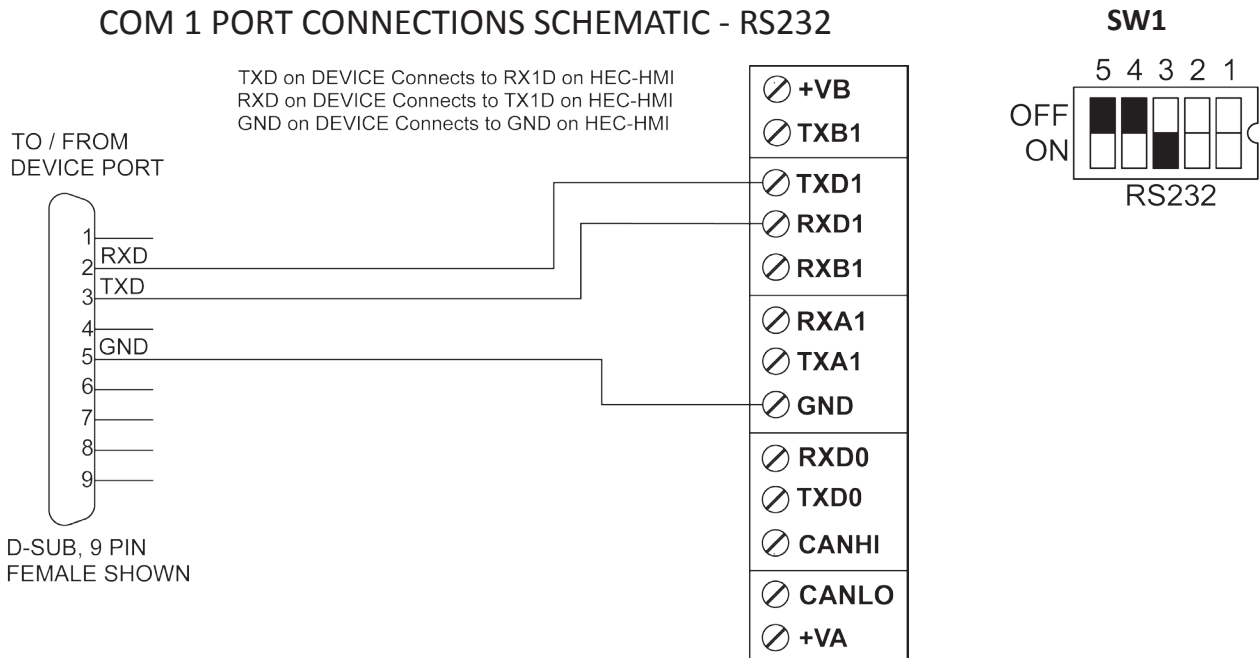

Figure 14 - COM1 RS232 Port Connections

COM 1 PORT CONNECTIONS SCHEMATIC - RS422

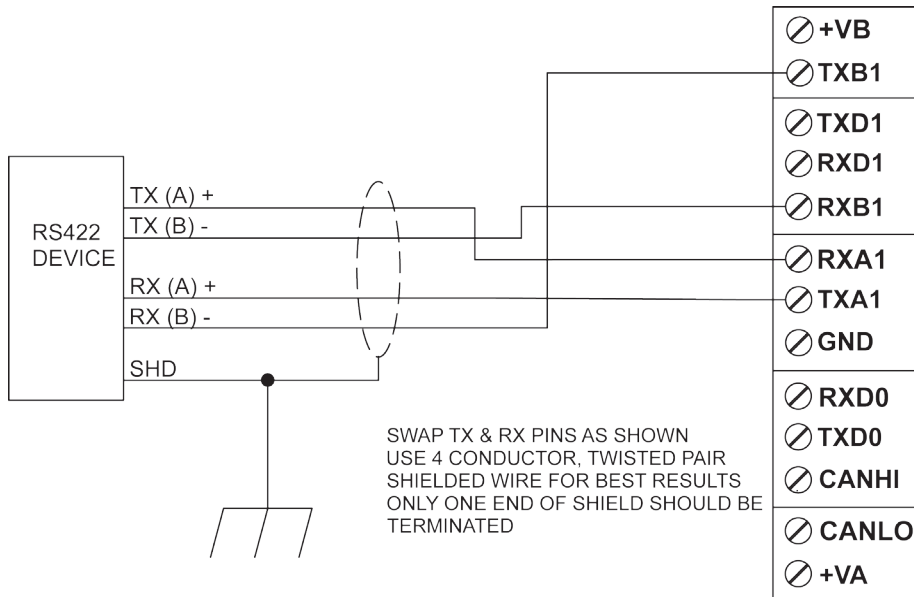

Figure 15 - COM1 RS422 Port Connections

COM 1 PORT CONNECTIONS SCHEMATIC - RS485

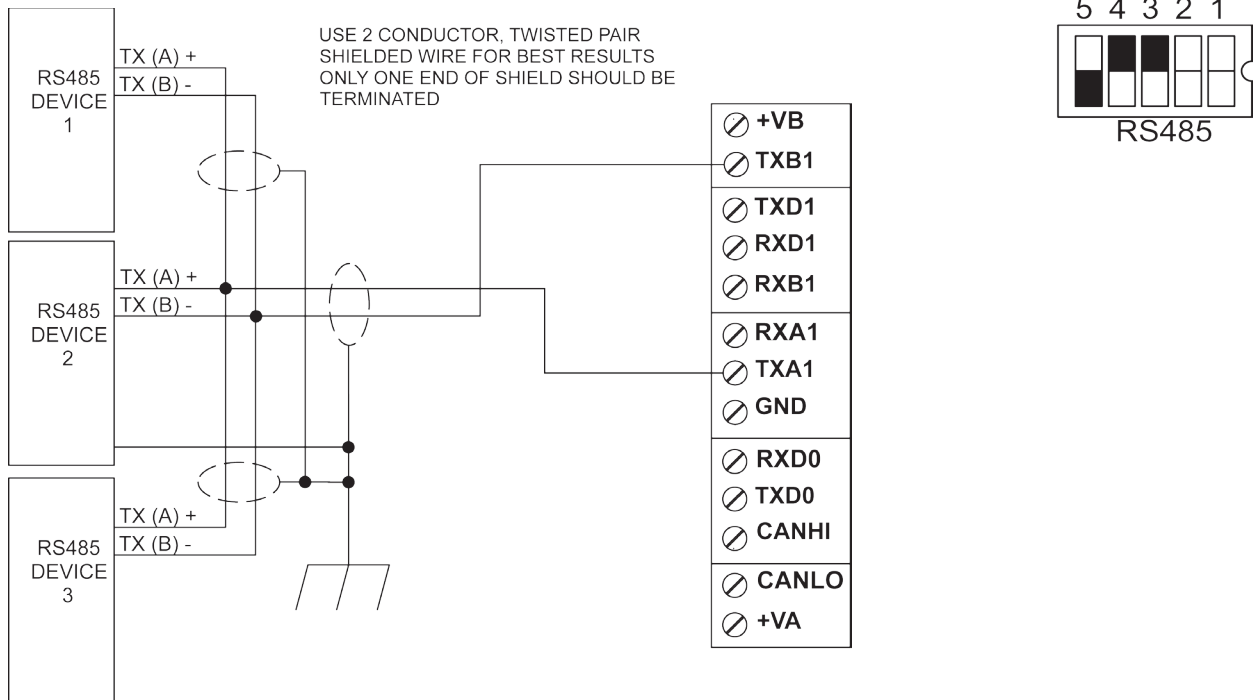

Figure 16 - COM1 RS485 Port Connections

! In the event you are connecting the General Purpose Serial Port (COM1) to another smart device that needs to be powered externally, the HEC-HMI provides a power out terminal (labeled +VB). The +VB will supply either 5VDC or the HEC-HMI's input voltage (with reverse bias protection) based on the field selectable jumper JMP2. To set this jumper, the unit must be dis-assembled. See the HEC-HMI Assembly / Disassembly section of this manual.

⊘ If the incorrect voltage is selected a connected device could be damaged from over-voltage!

Configure the jumper JMP2 as shown in Figure 17. Removing the jumper completely disconnects all power from the +VB terminal.

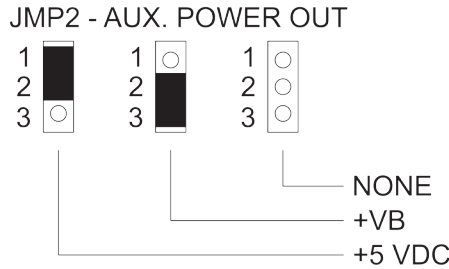

Figure 17 - COM1 +VB Power Output Option

OptiCAN Port / J1939 Port

The HEC-HMI can communicate to other devices using it's on-board CAN bus port. This port supports the J1939 Protocol and the Divelbiss OptiCAN Protocol.

The CAN bus port may be connected to any J1939 bus, allowing the HEC-HMI to monitor and receive J1939 data broadcasts from engines, transmissions and more. Refer to the EZ LADDER Manual for 1939 supported features.

The OptiCAN Protocol is a proprietary communication protocol for allowing communications between the HEC-HMI, Controllers and I/O devices. It is a register based broadcast system. Refer to the EZ LADDER Manual for more details regarding OptiCAN.

Regardless of the bus used, Figures 18 and Figure 19 are typical diagrams for the CAN port.

CAN PORT CONNECTIONS SCHEMATIC

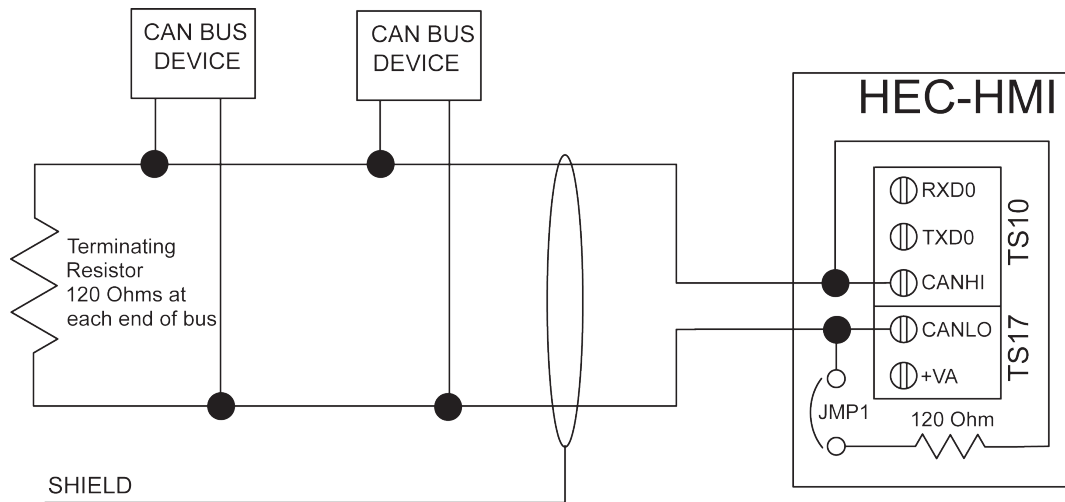

Figure 18 - CAN Port Connections

CAN PORT CONNECTIONS WIRING

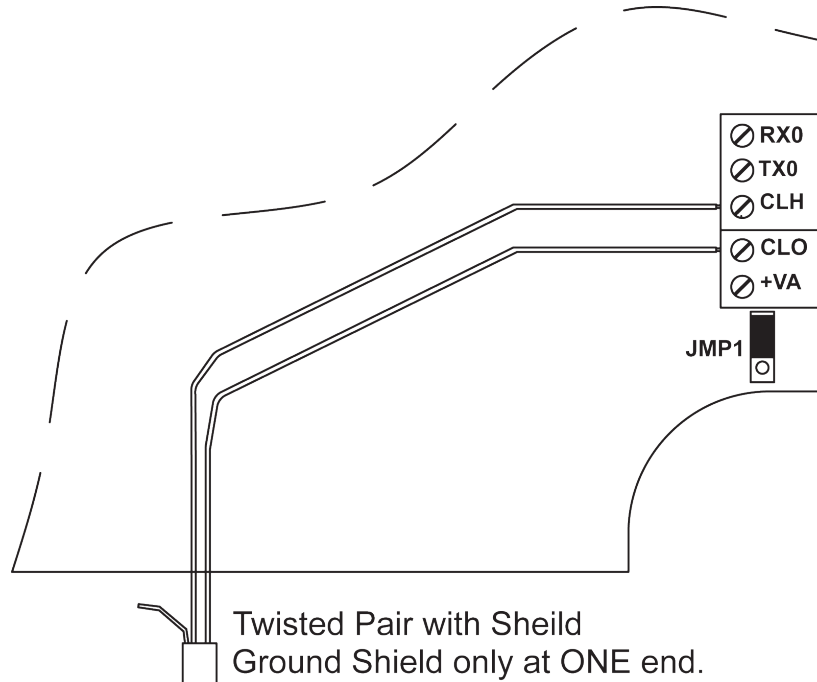

Figure 19 - Typical CAN Port Wiring

For the CAN bus to operate properly, terminating resistors at each end of the bus are required (typically 120 ohms each). The HEC-HMI can internally provide the 120 ohm terminating resistor as an option. If the HEC-HMI is physically wired at one of the bus ends, set the internal JMP1 jumper to enable the terminating resistor as shown in Figure 19. If the HEC-HMI is not physically wired at one of the bus ends, set the internal JMP1 jumper to disable the terminating resistor as shown in Figure 20.

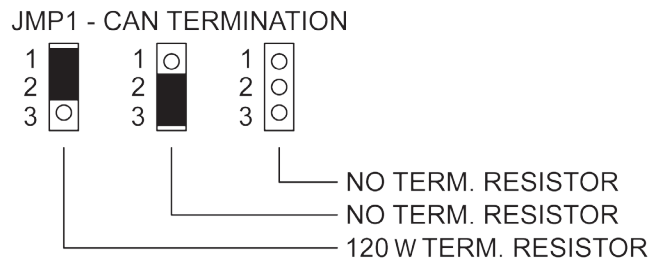

Figure 20 - CAN Port Terminating Resistor Option

User Interface

This section explains the features and basics of the user interface which includes the

- LCD display
- Backlight Control
- Heater Control
- Status LEDs
- Programmable Buttons
- Programmable LEDs
- Programmable Horn

HMI Display

The HEC-HMI boasts a large font, 2 line, 16 character or a regular font, 4 line, 20 character display. This display has a backlight which is controlled in the ladder diagram project.



To display text and data on the display, the HEC-HMI uses the **LCD_PRINT** and **LCD_CLEAR** function blocks. Using these blocks to control the display, text and variables can be displayed and updated as an entire row or can be updated starting with a particular column. The **LCD_PRINT** function text is formatted per ANSI C *printf* which provides flexibility. When printing to the display, the first row (at the top) is always Row 0 and the first column (at the left) is always Column 0.

For details on printing and clearing the display, refer to the EZ LADDER User's Manual. It provides details on the LCD display printing and function blocks including formatting control.

For details on printing and clearing the display, refer to the EZ LADDER User's Manual. It provides details on the LCD display printing and function blocks including formatting control.



Programs with sample displays blocks and menus can be found in the [HEC-HMI Resource Zip](http://www.divelbiss.com) file from our website (<http://www.divelbiss.com>).



The HEC-HMI's display will function between -40°C and 80°C. Temperatures below 0°C may result in decreased display speed performance while temperatures above 70°C may result in decreased display contrast.

Display Contrast Control

The HEC-HMI's display contrast is controlled automatically by internal circuits. It will automatically adjust the contrast based on changes in temperature. The contrast setting is factory set for optimal viewing based generally normal temperature ranges. No adjustment should be required.

Display Backlight Control

The backlight for the HEC-HMI display is controlled in the ladder diagram project as a coil named **BKLGHT**. This coil (boolean variable) is automatically created when the HEC-HMI model is selected in the Project Settings. This provides the flexibility of turning off the backlight to conserve power when operating on batteries. By default, the backlight is turned off. It must be specifically turned on in the ladder diagram project as shown in Figure 21. An example of this program can be found in the [HEC-HMI Resource Zip](http://www.divelbiss.com) file from our website (<http://www.divelbiss.com>).

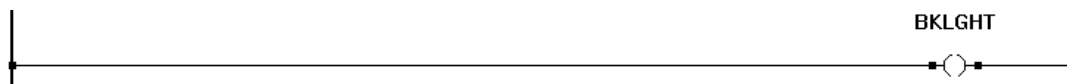

Figure 21 - Backlight Control Ladder Diagram

Programmable LEDs

Four programmable LED Indicators (labeled 1 through 4) on the HEC-HMI's front are provided to aid in the user interface experience. These indicators are controlled by coils in the ladder diagram program. These coils (boolean variables LED1, LED2, LED3 and LED4) are automatically created when the HEC-HMI model is selected in the Project Settings. Each LED indicator is individually controlled by its coil as shown in Figure 22. An example of this program can be found in the [HEC-HMI Resource Zip](http://www.divelbiss.com) file from our website (<http://www.divelbiss.com>).





Figure 22 - Programmable LEDs Control - Ladder Diagram

Status LEDs

Two status LED's; PWR and WD are provided on the front of the HEC-HMI to alert the status of the HEC-HMI's condition. Both are green indicator LEDs.



 The PWR Indicator will be illuminated when the input power is within acceptable range (8-32VDC). If the PWR Indicator is dark, check the input voltage. If the input voltage is within the normal range, contact Divalbiss Support to have your HEC-HMI serviced.

 The WD Indicator identifies the current status of the HEC-HMI. If the WD Indicator is flickering quickly, this indicates that there has been no kernel loaded on the HEC-HMI. Load the kernel (See Loading the HEC-HMI Kernel section of this manual).

 If the WD Indicator is flashing slowly, this indicates the kernel is loaded and the HEC-HMI is waiting for a ladder diagram to be downloaded (has no program) or that the ladder program is not executing (loaded but not running). To correct this issue, download the program or cause the program to restart by cycling power or clicking the **GO** button in EZ LADDER Toolkit (when in the Run mode and connected to the target).

 If the WD Indicator is flashing quickly (about 10 times per second), this indicates the kernel and ladder program is loaded and the ladder program is executing (running).

Programmable Buttons

The HEC-HMI provides a total of Nine programmable buttons. Five of the buttons are placed to serve as general navigation buttons (Up, Down, Left, Right and Enter (Center)). These are ideal for scrolling through messages and menus. While these buttons were generally placed for navigation, they may be used for any purpose in the ladder diagram project. These buttons are used in the ladder diagram as digital inputs. Contacts (boolean variables) for each button are automatically created when the HEC-HMI model is selected in the Project Settings. These variables are PBLT (Left), PBRT (Right), PBUP (Up), PBDN (Down) and PBENT (Center).



The four remaining buttons are placed to serve as general use buttons. Each button may be programmed and used for any purpose in the ladder diagram project. These buttons are used in the ladder diagram as digital inputs. Contacts (boolean variables) for each button are automatically created when the HEC-HMI model is selected in the Project Settings. These variables are F1 (F1), F2 (F2), F3 (F3) and F4 (F4).



Any of the programmable button contacts may be used in the ladder diagram the same as any other contact as shown. Refer to Figure 23 for a sample of how to use the programmable buttons.

 Programs with sample menus using the programmable buttons can be found in the [HEC-HMI Resource Zip](http://www.divelbiss.com) file from our website (<http://www.divelbiss.com>).

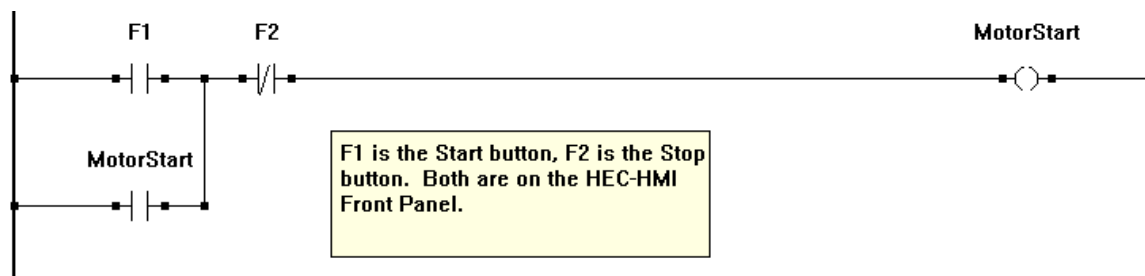

Figure 23 - Programmable Buttons - Ladder Diagram

Display Heater Control

To gain the full range of operation on the HEC-HMI, the display has an internal heater. When enabled, the heater will monitor the temperature and will turn-on when the temperature is at or below 0°C (approximate temperature, typically between 5°C and -5°C). The heater can be enabled or disabled by an internal switch that is found on SW1. To change the heater setting, the unit must be dis-assembled. Refer to the HEC-HMI Assembly/Disassembly part of this manual. By default, the heater is factory shipped as enabled, but can be disabled if desired by changing the switch setting as shown in Figure 24.

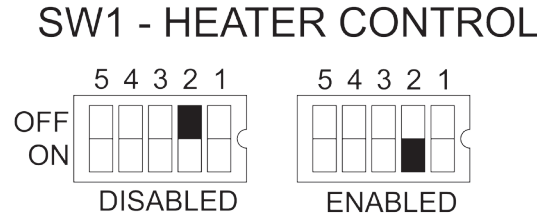

Figure 24 - Field Selectable Heater On/Off Control

Programmable Horn

A programmable horn is provided for audible feedback situations. The horn is controlled in the ladder diagram project by it's coil. The duration the horn is active is controlled only by the horn's coil. The horn's frequency is factory set and cannot be changed.



To control the horn, use the horn's coil (boolean variable BEEP) in the ladder program as shown. The BEEP (boolean variable) for the horn is automatically created when the HEC-HMI model is selected in the Project Settings. Refer to Figure 25.

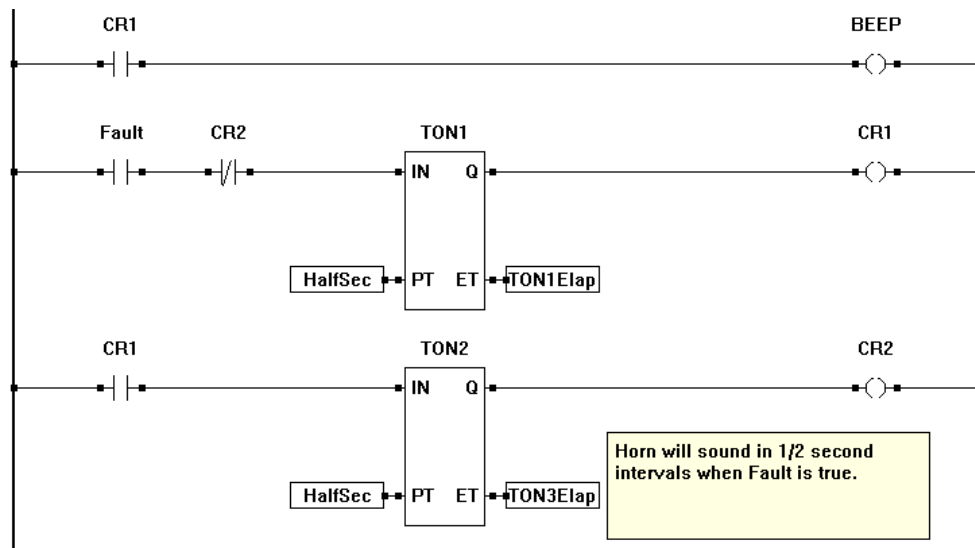

Figure 25 - Programmable Horn - Ladder Diagram

Memory

This section explains the HEC-HMI memory structure and provides details on the amount and types of memory that can be used in the HEC-HMI.

Memory Overview

The HEC-HMI, as with all other smart devices, requires different types of memory to operate. The HEC-HMI uses the on-board memory types of the PLC on a Chip™ processor. The PLC on a Chip™ provides both RAM and FLASH memory. These two types of memory are the basis for all the memory used in the HEC-HMI.

RAM Memory

The HEC-HMI provides 4K bytes (4096 bytes) of RAM. This RAM is the memory the HEC-HMI actually uses to run the ladder diagram. As functions and objects (function blocks, variables, etc.) are added to a ladder diagram, some require bits of RAM to operate while some do not. As the program grows, the amount of unused RAM will decrease.

There is no RAM expansion for the HEC-HMI. In all but few applications, the 4K of RAM will be plenty to complete a program of thousands of rungs. The determining factor is the mix of variables and functions that use RAM. For example, the Drum_Sequencer function will use more RAM than many blocks.



To determine how much RAM is used and how much is still available, in EZ LADDER Toolkit, **COMPILE** the program. The Output Window will display the amount of RAM that is used and available. If program errors are present, correct the errors and then **COMPILE**. See the example provided in Figure 26.



By default, all variables in a program reside in this RAM and this memory is volatile; meaning if power is lost, the actual contents in the variables will be lost.

FLASH Memory

The HEC-HMI provides 64K bytes of FLASH. This memory is where the actual ladder diagram program will reside (is stored) when loaded into the HEC-HMI. This memory cannot be accessed by the user except as a direct result of the ladder diagram size and being downloaded into the HEC-HMI. As the ladder diagram size grows, so does the amount of FLASH required to store it.



There is no FLASH expansion for the HEC-HMI. In all but few applications, the 64K of FLASH will be plenty to complete a program of thousands of rungs.

To determine how much FLASH is used and how much is still available, in EZ LADDER Toolkit, **COMPILE** the program. The Output Window will display the amount of FLASH that is used and available. If program errors are present, correct the errors and then **COMPILE**. See the example provided in Figure 26.

```
x Starting verify.  
End verify.  
Starting compile  
RAM bytes used: 138, RAM bytes left: 3958  
ROM bytes used: 977, ROM bytes left: 64559  
Retentive EEPROM bytes used: 0, bytes left: 100  
End compile
```

Figure 26 - Memory Usage

Retentive Memory

As one of the standard features of PLC on a Chip™ and EZ LADDER Toolkit, the HEC-HMI supports the use of Retentive memory. The HEC-HMI provides 100 bytes of Retentive Memory. This memory actually resides in a PLC on a Chip™ as an EEPROM memory block. This retentive memory is used to store variables and functions (make variables and functions retentive) whose values or contents must be maintained when power is lost.

 To make variables or functions retentive, a checkbox is provided in the Variable Dialog box (or the Function Properties box). Once this box is checked, the variable or function is now retentive. When the HEC-HMI detects a power loss, it will automatically store all these retentive variables (functions) and when power is restored, it will automatically reload all these variables (functions).

As only 100 bytes total is available for Retentive memory. Boolean variables use 2 bytes each, Real and Integer variables use 4 bytes each. Refer to the EZ LADDER Toolkit User's Manual for more details regarding variables, function and retentive memory.

 To determine how much Retentive EEPROM is used and how much is still available, in EZ LADDER Toolkit, **COMPILE** the program. The Output Window will display the amount of Retentive EEPROM that is used and available. If program errors are present, correct the errors and then **COMPILE**. See the example provided in Figure 26.

EEPROM Memory

As one of the standard features of PLC on a Chip™ and EZ LADDER Toolkit, the HEC-HMI supports the use EEPROM memory that may be used to store and recall boolean, integer, real and timer values in non-volatile memory in the ladder diagram. This can be used to store field adjustable set points and more.

The HEC-HMI supports 2792 bytes of EEPROM memory. This memory is accessed in the ladder diagram using the EEPROM_READ and EEPROM_WRITE Function blocks. The same variable type that writes to the EEPROM location should be used to read the EEPROM location. A memory map is recommended for organizing variables stored in EEPROM.

 Each EEPROM address is absolute and is one byte in size. Boolean variables fill two bytes while all other variable types fill four bytes of EEPROM. When writing a boolean to address 0, the actual variable will use addresses 0 and 1 (two bytes). Should you write an integer variable into address 0, then it would use addresses 0-3. A memory map should be created and used to assign variable types and addresses prior to coding to ensure that variable size and types are accounted for.

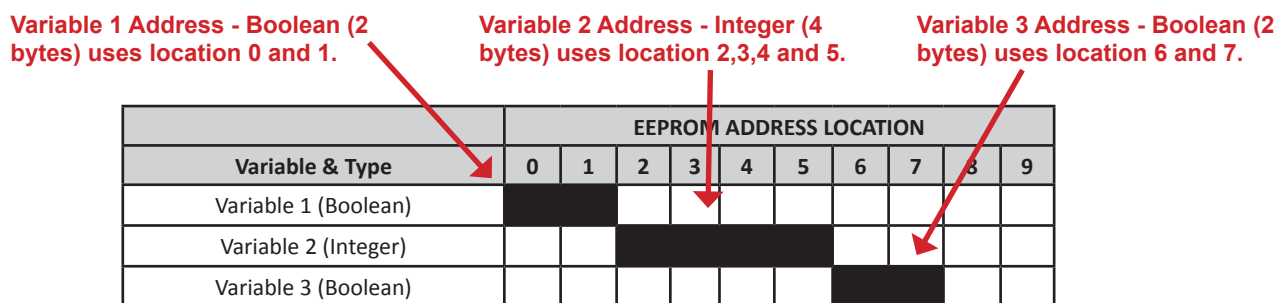



Figure 27 - EEPROM Memory Locations

 EEPROM storage area has a limited number of write cycles; therefore it shouldn't be used to store data which changes often and must be re-written often. Writing often to the same location can cause the location to fail.

Digital I/O

This section will explain the HEC-HMI Controller's Digital I/O including:

- Digital Inputs
- High Speed Counter Inputs
- Digital Input De-bounce
- Solid-State Digital Outputs
- Relay Outputs
- PWM Outputs

Digital Inputs Overview

The HEC-HMI with Controller includes six digital inputs. These six inputs are grouped into two categories; dedicated inputs and multi-use inputs. There are two multi-use inputs and four dedicated inputs. For EZ LADDER Toolkit Digital Inputs, GPI is a general term used to represent **General Purpose Input**. The HEC-HMI's inputs are labeled using the same GPI format to match the contacts (boolean variables) in EZ LADDER Toolkit.

These digital inputs are connected to via the internal terminal blocks provided. Each terminal is rated for 10 Amps and can accept from 26 AWG to 16 AWG wire size. The digital inputs are located on TS15, TS16 and TS8. See the HEC-HMI Basics section for a diagram of locations of the terminal blocks.

Dedicated Inputs

The HEC-HMI with Controller includes six digital inputs. Of these six digital inputs, four are dedicated inputs; meaning they are always digital inputs. Each of these inputs are sinking and will operate from 8-32VDC. Each of the dedicated inputs is designed with approximately a 20 millisecond de-bounce.

As these inputs are sinking, they require voltage on the input to energize it. The presence of this voltage on an input will result in the input being read as TRUE in the ladder diagram. Refer to the Figure 28 for Dedicated Digital Input Connections.

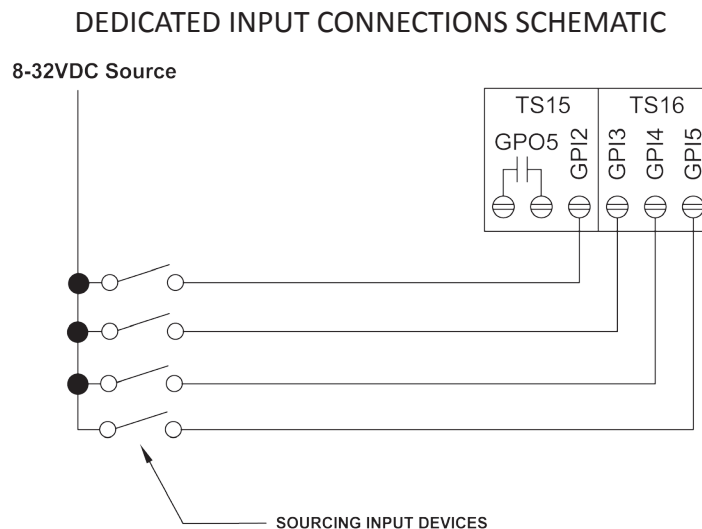

Figure 28 - Dedicated Digital Input Connections Schematic

To read a digital input in a ladder diagram, place and connect the appropriate contact for your needs. The DIRECT CONTACT and INVERTED CONTACT functions are used to read digital inputs in the ladder diagram. When placing the contact, verify you select the correct input variable(GPI2- GPI5) from the provided drop-down menu. These boolean variables that represent the dedicated digital inputs are automatically created when the HEC-HMI Controller (by model number) target is selected in the Project Settings.

Multi-Use Inputs as Digital Inputs

The HEC-HMI with Controller includes six digital inputs. Of these six digital inputs, two (GPIO and GPI1) can function as either standard digital inputs or as High Speed Counter Inputs. Regardless if two inputs are being used as Digital Inputs or High Speed Counter Inputs, the same terminals are used (CNT1/GPIO, CNT2/GPI1).

As GPIO and GPI1 are dual function inputs that operate as digital inputs or high speed counter inputs, each input has a de-bounce circuit that can be enabled or disabled. The de-bounce circuit is disabled by default as if the inputs were to be used as high speed counters. If using GPIO or GPI1 as a standard digital input, the de-bounce circuit should be enabled. To enable the de-bounce circuit, you must energize the coil (boolean variable) for the counter input de-bounce. These boolean variables, GPIO_DEB and GPI1_DEB are automatically created when the HEC-HMI Controller (by model number) target is selected in the Project Settings.

When the GPIO_DEB or GPI1_DEB coils are true, the de-bounce for the input is active. When false, the de-bounce is not active. Refer to Figure 29.

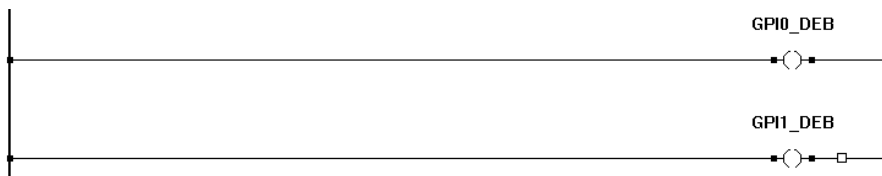

Figure 29 - GPIO/GPI1 De-bounce Control - Ladder Diagram

The GPIO and GPI1 inputs must be configured for the supply voltage. There are two input voltage ranges that are supported: 2.5VDC to 5VDC and 5VDC to 32VDC. The input voltage range is field selectable using the internal SW2 switch block. This switch block will allow the individual selection for each of the GPIO and GPI1 inputs. The GPIO and GPI1 input voltage is factory set for 5-32VDC range. Refer to Figure 30.

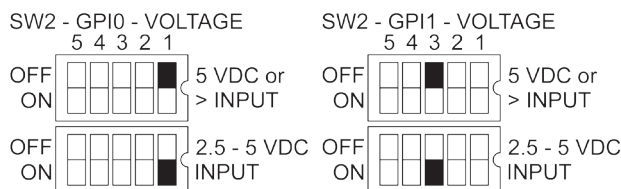

Figure 30 - GPIO/GPI1 Field Selectable Voltage Options

The GPIO and GPI1 inputs can accept a signal from an NPN or PNP device. This is controlled by the internal SW2 switch block. This block will allow for individual selection for each of the GPIO and GPI1 inputs. The NPN/PNP setting is factory default to PNP. Refer to Figure 31.

For PNP input devices, they will source the voltage the input requires (sinking input, sourcing device). When using this mode, the input contacts will act as all other digital inputs with a True condition in the ladder diagram when voltage is applied to the input. Figure 32 is diagram of the Internal GPIO / GPI1 Circuit.

For NPN input devices, they will sink the input source (sourcing input, sinking device). An internal pull-up resistor is provided for connecting to NPN devices. Figure 32 is a diagram of the Internal GPIO / GPI1 Circuit. When using this mode, the input contacts will be reversed from all other digital inputs with a False condition in the ladder diagram when actual input is active and True condition in the ladder diagram when the actual input is not active.

For proper operation, it is important to configure the GPIO and GPI1 input settings for both input voltage and type. If the input settings do not correspond the actual input, the input may not operate as expected and the HEC-HMI may be damaged.

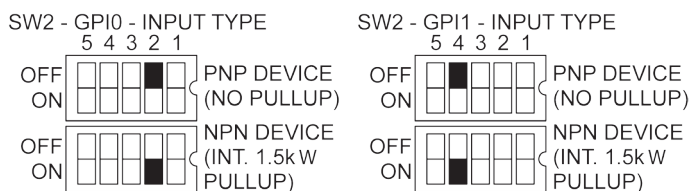

Figure 31 - GPIO/GPI1 Field Selectable Input Type

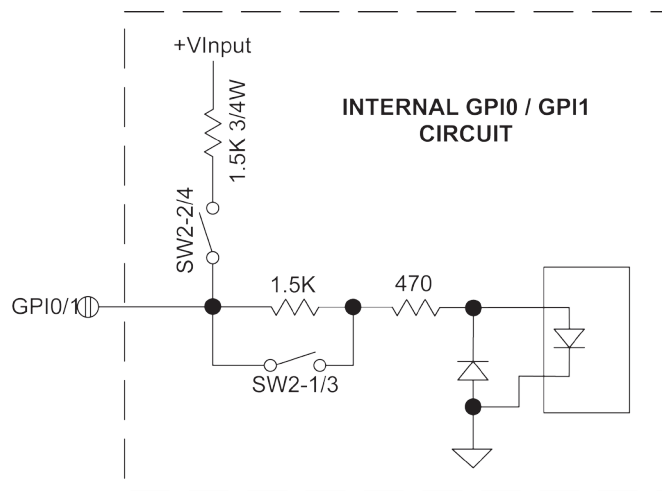

Figure 32 - GPIO/GPI1 Typical Input Circuit



Please note: Individually, the GPIO and GPI1 inputs are designed to be used as a digital input only or high speed counter input only. EZ LADDER Toolkit will allow the placement of contacts and /or CNTRTMR function in any program. Therefore, you can place and use the contacts and the CNTRTMR function block in the same program with the same digital input selected. This can be useful in some programs based on the application, but it is important to know that input contacts will only operate at a fraction of the frequency that the CNTRTMR function block can accurately read.



Unlike the dedicated digital inputs that are sinking only, the GPIO and GPI1 can operate as sinking or sourcing based on how the NPN / PNP settings are configured. Figure 33 provides examples of settings and connections for NPN and PNP devices.

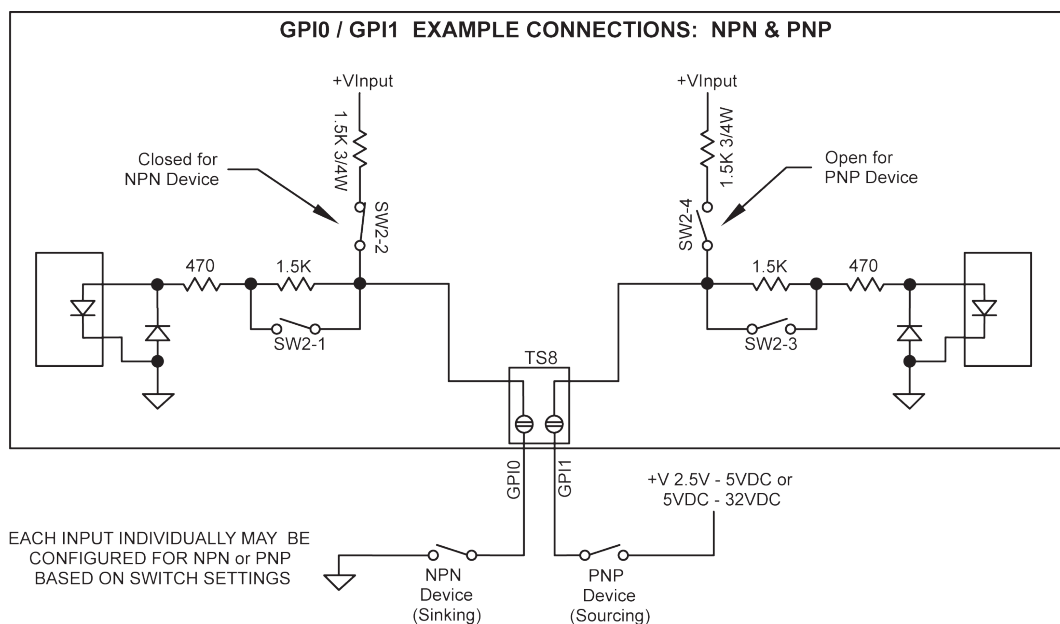

Figure 33 - GPIO/GPI1 Connections - NPN/PNP

To read a digital input in a ladder diagram (both dedicated and multi-use as a digital inputs), place and connect the appropriate contact for your needs. The DIRECT CONTACT and INVERTED CONTACT functions are used to read digital inputs in the ladder diagram. When placing the contact, verify you select the correct input variable(GPIO- GPI1) from the provided drop-down menu.

These boolean variables that represent the digital inputs are automatically created when the HEC-HMI Controller (by model number) target is selected in the Project Settings. Figure 34 is a typical ladder diagram program using a GPI digital input.

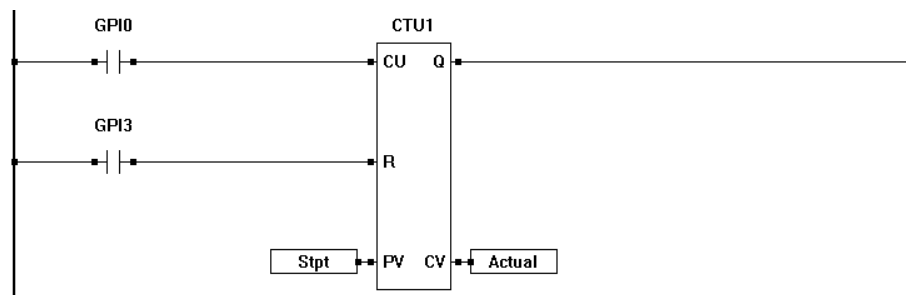

Figure 34 - Using Digital Inputs in EZ LADDER Toolkit

Multi-Use Inputs as High Speed Counter Inputs

The HEC-HMI with Controller includes six digital inputs. Of these six digital inputs, two (GPI0 and GPI1) can function as either standard digital inputs or as High Speed Counter Inputs. Regardless if these inputs are being used as Digital Inputs or High Speed Counter Inputs, the same terminals are used (CNT1/GPI0, CNT2/GPI1).

As GPI0 and GPI1 are dual function inputs that operate as digital inputs or high speed counter inputs, each input has a de-bounce circuit that can be enabled or disabled. The de-bounce circuit is disabled by default as if the inputs were to be used as high speed counters. The de-bounce is only controlled in the ladder diagram using the GPI0_DEB and GPI1_DEB coils. No hardware settings for de-bounce are required.

CNT1 (GPI0) and CNT2 (GPI1) may be utilized as high speed counters (up counting only). These inputs will accept a maximum frequency of 250KHz and are optically isolated to promote noise immunity. These inputs are ideal to anywhere that high speed counting is required; such as calculating RPM, batch counting and more.

The CNT1 and CNT2 inputs must be configured for the supply voltage. There are two input voltage ranges that are supported: 2.5VDC to 5VDC and 5VDC to 32VDC. The input voltage range is field selectable using the internal SW2 switch block. This switch block will allow the individual selection for each of the GPI0 and GPI1 inputs. The CNT1 and CNT2 input voltage is factory set for 5-32VDC range. The 2.5-5VDC range would typically be used for lower power devices such as hall-effect sensors. Refer to Figure 35.

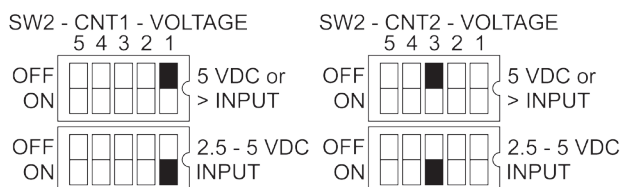

Figure 35 - CNT1/CNT2 Field Selectable Input Voltage

The CNT1 and CNT2 as counters can will accept a signal from an NPN or PNP device. This is controlled by the internal SW2 switch block. This block will allow for individual selection for each of the CNT1 and CNT2 inputs. The NPN/PNP setting is factory default to PNP.

For PNP input devices, they will source the voltage the input requires (sinking input, sourcing device). For NPN input devices, they will sink the input source (sourcing input, sinking device). An internal pull-up resistor is provided for connecting to NPN devices. See the provided diagram of the Internal CNT1 / CNT2 Circuit. Refer to Figure 36.

For proper operation, it is important to configure the CNT1 and CNT2 input settings for both input voltage and type. If the input settings do not correspond the actual device, the counter input may not operate as expected and the HEC-HMI may be damaged.

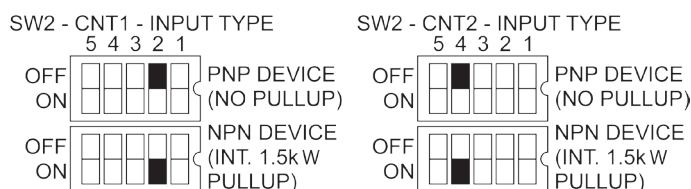

Figure 36 - CNT1/CNT2 Field Selectable Input Type

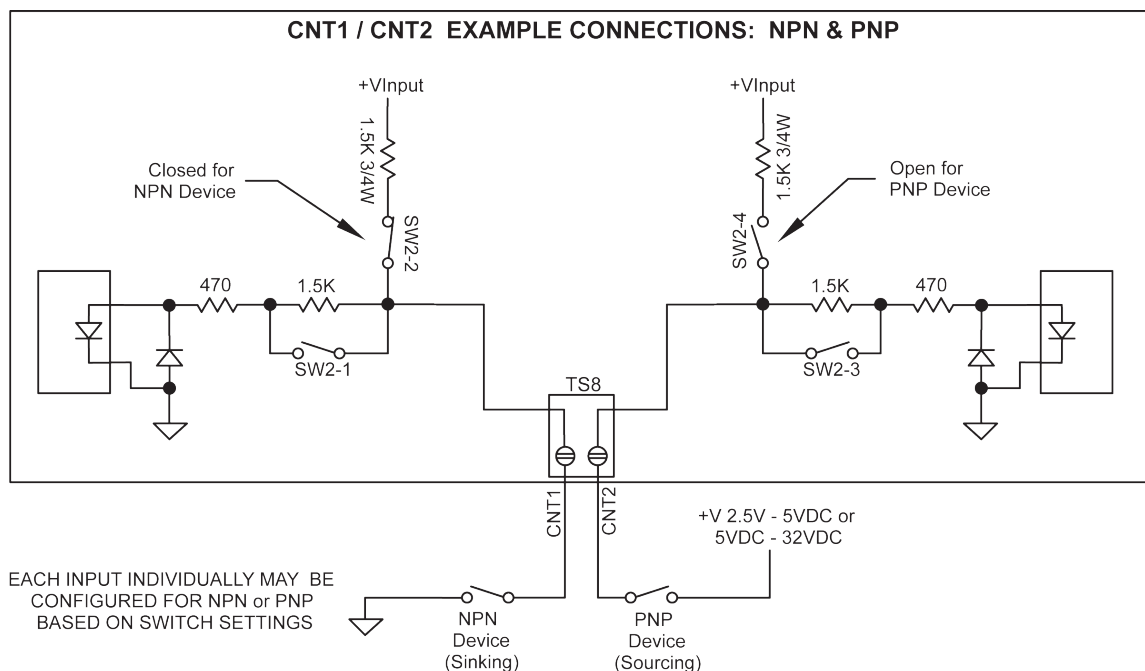



Figure 37 - CNT1/CNT2 Connections - NPN/PNP

To use CNT1 or CNT2 in a ladder diagram as a high speed counter, you must use the CNTRTMR function block. This block, when placed in the ladder diagram, will provide a drop-down menu to select which counter to use. Refer to the EZ LADDER Toolkit User’s Manual for details on the CNTRTMR and other function blocks. CNT1 is Counter Channel 1 while CNT2 is Counter Channel 2 in the CNTRTMR function block. Figure 28 is a typical High Speed Timer Circuit in EZ LADDER.

 Please note: Individually, the GPIO/CNT1 and GPIO/CNT2 inputs are designed to be used as a digital input only or high speed counter input only. EZ LADDER will allow the placement of contacts and /or CNTRTMR function in any program. Therefore, you can place and use the contacts and the CNTRTMR function block in the same program with the same digital input selected. This can be useful in some programs based on the application, but it is important to know that input contacts will only operate at a fraction of the frequency that the CNTRTMR function block can accurately read.

 The High Speed Counter Inputs CNT1 and CNT2 can operate as sinking or sourcing based on how the NPN / PNP settings are configured. Figure 37 is an example of both NPN and PNP connections.

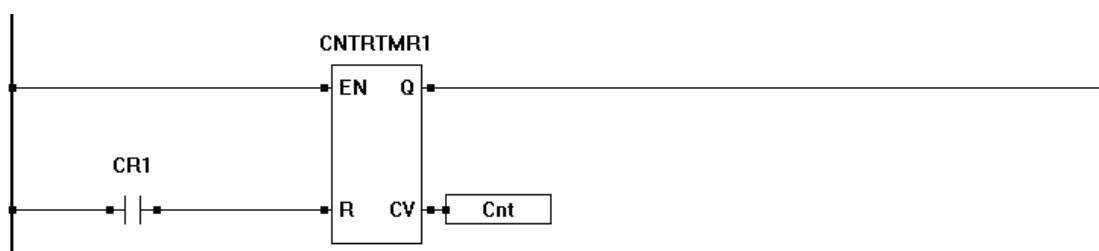

Figure 38 - Using Counter Inputs in EZ LADDER

Digital Outputs Overview

The HEC-HMI with Controller provides six digital outputs. These six outputs are grouped into two categories; solid-state sourcing outputs with PWM capability and dry-contact relay outputs. GPO is a general term used to represent **General Purpose Output**. The HEC-HMI's outputs are labeled using the same GPO format to match the coils (boolean variables) in EZ LADDER Toolkit.

These digital outputs are connected to via the internal terminal blocks provided. Each terminal is rated for 10 Amps and can accept from 26 AWG to 16 AWG wire size. The digital inputs are located on TS13, TS14 and TS15. See the HEC-HMI Basics section for a diagram of locations of the terminal blocks.

Solid-State Digital Outputs as General Purpose Outputs

The HEC-HMI with Controller provides six digital outputs. Of these six digital outputs, four are solid-state; meaning they do not have mechanical moving parts (contacts).

 Each of the solid-state outputs may be used as either digital outputs that operate as an ON/OFF function using coils in the ladder diagram program or Pulse Width Modulation Outputs (PWM) using the PWM blocks in the ladder diagram. For general ON/OFF control needs, it is recommended that the GPO coils be used. When controlling devices such as valves, where you want to control the open/close amount in a closed loop system, Pulse Width Modulation is recommended.

These outputs are identified in the EZ LADDER Toolkit and this manual as GPO0 - GPO3. These outputs are sourcing, therefore an energized output will source an output voltage equal to the controller input voltage.

 Each output can drive a load up to maximum current rating listed in the specifications section (Refer to Output De-Rating diagram, Figure 40 for current and temperature ratings) and includes an automatic over-current shutdown safety. In the event an over current condition exists, the output will shut down. This shut down condition is reset when the output is turned off (set to false) in the ladder diagram. Loads are based on output pairs (GPO0 & GPO1, GPO2 & GPO3).

 Each output requires a minimum load to operate correctly. Depending upon the device connected to an output, a minimum load resistor may be required. If the output is ON or true regardless of the ladder diagram program, connect a 470Ω to 1KΩ load from the output to input power common.

As each digital output (GPO0 - GPO3) may be configured and used as a digital output or as a Pulse Width Modulation (PWM). Each of these four outputs may only be used as either digital output or PWM output only. For information on using digital outputs as PWM outputs, refer to the Pulse Width Modulation Outputs Section of this manual.

 Commutating diodes should be installed on all output channels for noise immunity. If using current feedback, these diodes must be installed for the feedback reading to be correct.

 Additionally, GPO0 - GPO3 also have current sense feedback capability using analog inputs (AN4-AN7 respectively). These analog inputs can be utilized in the program as control parameters and their resolution is based on the analog inputs resolution of the HEC-HMI model.

Refer to the Solid-State Output Connections Schematic - Figure 39.

SOLID-STATE OUTPUT CONNECTIONS SCHEMATIC

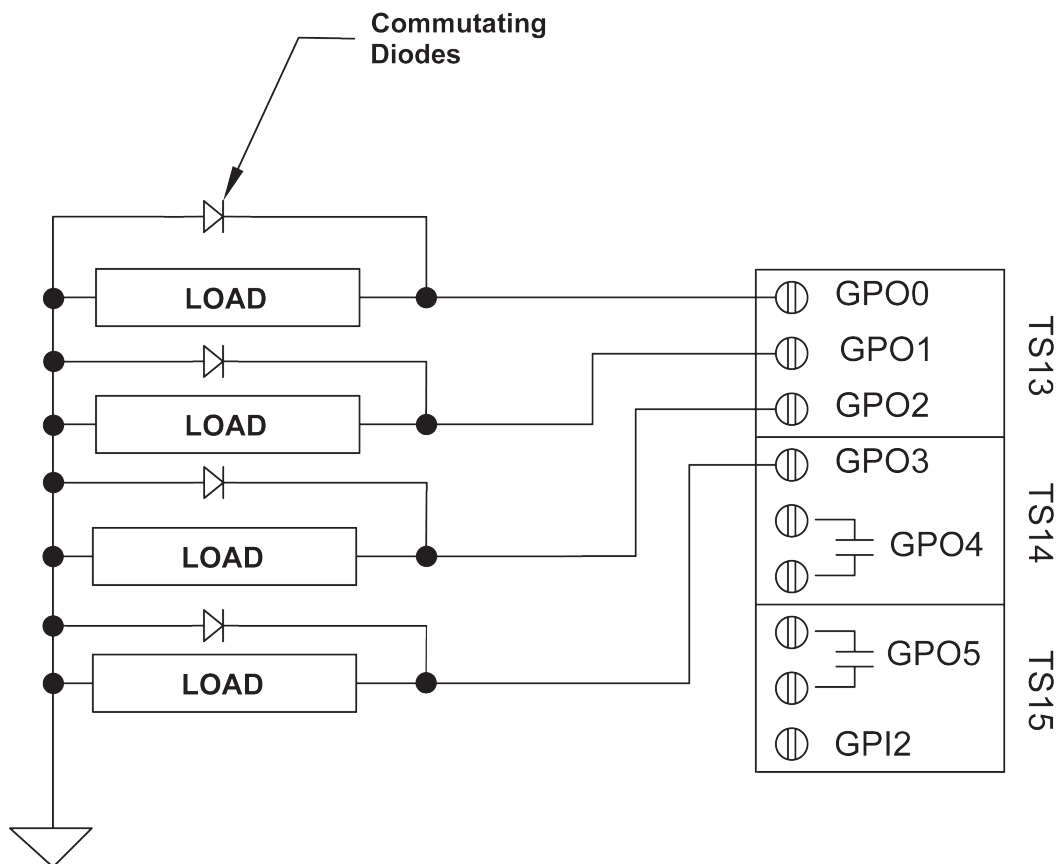

Figure 39 - Solid-State Outputs Connection Schematic - GPO or PWM

SOLID-STATE OUTPUT DE-RATING - LOAD & TEMPERATURE

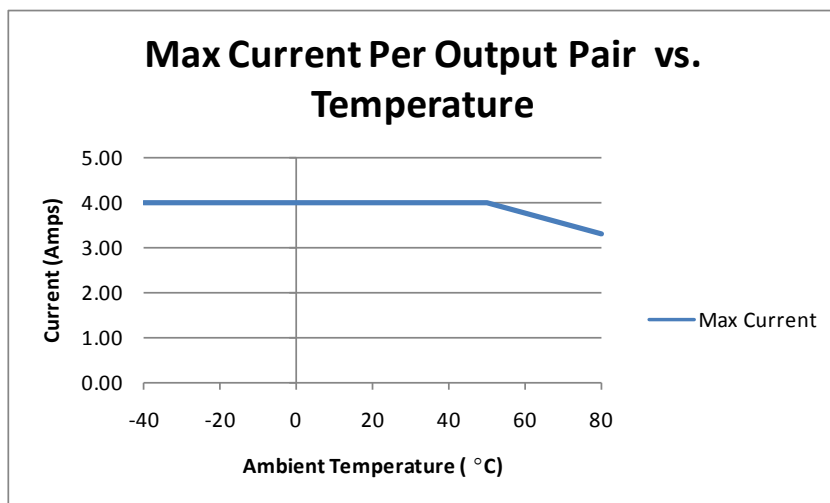

Figure 40 - Solid-State Output De-Rating Curve

To control a digital output in a ladder diagram, place and connect the appropriate coil for your needs. The DIRECT COIL and INVERTED COIL functions are used to control digital outputs in the ladder diagram. When placing the coil, verify you select the correct output address (GPO0 - GPO3) from the provided drop-down menu. The GPO0 - GPO3 coils (boolean variables) are automatically created when the HEC-HMI model is selected in the Project Settings. Refer to Figure 41.



Figure 41 - Using Digital Outputs in EZ LADDER

When using the digital outputs on the HEC-HMI, regardless if used as digital outputs or PWM, if the total current of the outputs combined will exceed 8ADC, additional input power connections to the HEC-HMI are required. Refer to the Alternate Input Power Schematic and Wiring, Figure 42 and Figure 43 respectively.

ALTERNATE INPUT POWER SCHEMATIC

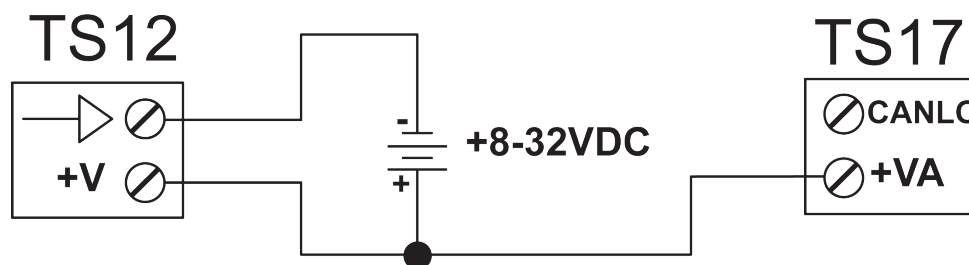

Figure 42 - Alternate Input Power Schematic for High Current Loads

ALTERNATE INPUT POWER WIRING

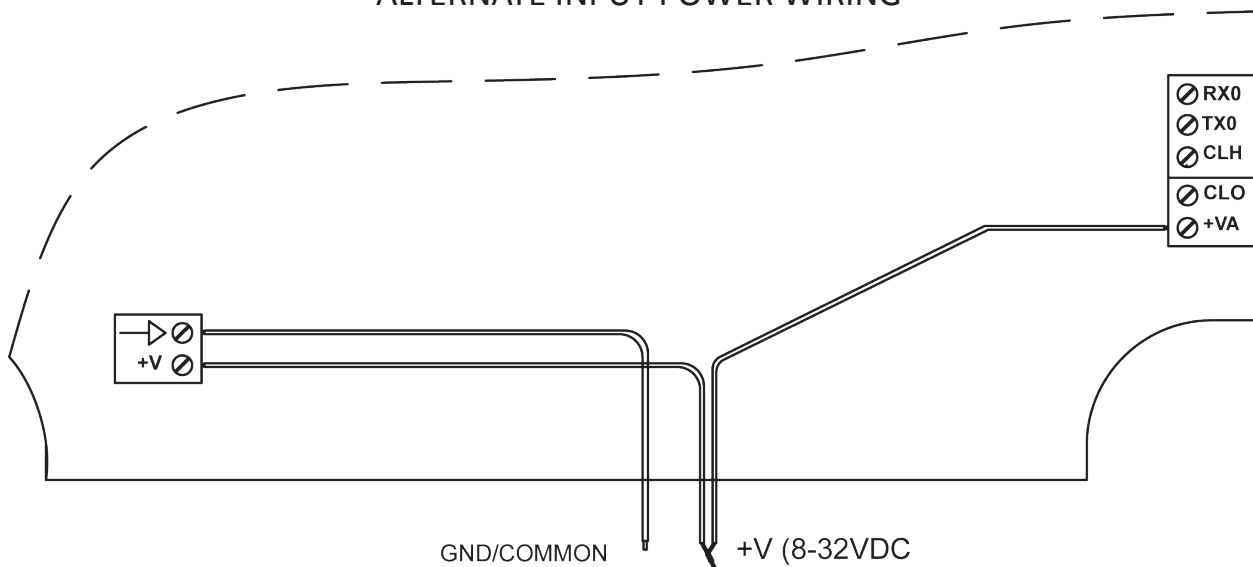

Figure 43 - Alternate Input Power Wiring for High Current Loads

Solid-State Digital Outputs as PWM

As previously noted, the HEC-HMI with Controller includes 4 on-board digital outputs that may be configured individually and exclusively as either digital outputs or pulse width modulation outputs; therefore, each output may only be used as either digital output or PWM output. Pulse Width Modulation Outputs allow for a base frequency with an adjustable Duty Cycle. The base frequency may be changed in the ladder diagram also.

Before Pulse Width Modulation outputs may be used in the ladder diagram, the Pulse Width Modulation Properties must be configured in EZ LADDER Toolkit.

To Configure Pulse Width Modulation (PWM) Outputs in EZ LADDER Toolkit:

1. In EZ LADDER, from the File Menu at the top, click **PROJECT** then **SETTINGS**. This will open the Project Settings Window. The HEC-HMI was previously selected.
2. Click the **PROPERTIES** button. The HEC-HMI Properties Window will open. Refer to Figure 44.

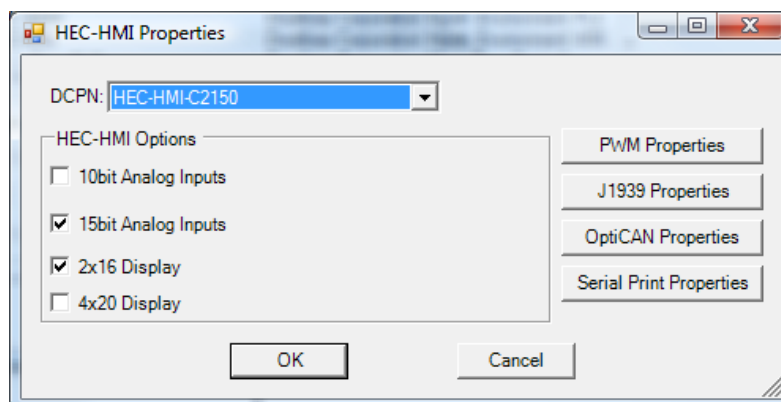

Figure 44 - HEC-HMI Properties Window

3. Click the **PWM PROPERTIES** button. The PWM Properties Window will open. Refer to Figure 45.

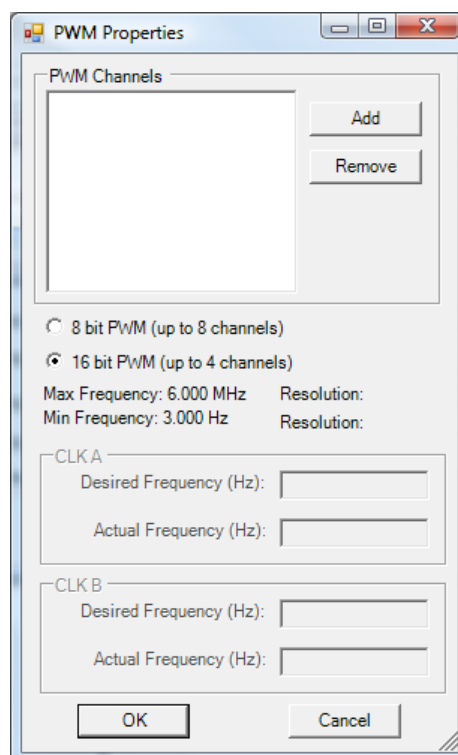

Figure 45- PWM Properties Window

4. Select the resolution of the PWM channels (8 or 16 bit). Only 4 channels are supported regardless of resolution. If an Expansion Option is installed and it's PWM channels are to be used, the resolution here must be set for 8 bit).
5. Click the **ADD** button in the PWM Properties window.
6. In the ADD PWM dialog, select the channels to install. To select multiple PWM channels, hold the CTRL key while clicking on the channel. Refer to Figure 46.

Only 4 PWM channels are supported, they are as follows:

Digital Output 0 (GPO0) is PWM 1 (in EZ LADDER)
 Digital Output 1 (GPO1) is PWM 3 (in EZ LADDER)
 Digital Output 2 (GPO2) is PWM 5 (in EZ LADDER)
 Digital Output 3 (GPO3) is PWM 7 (in EZ LADDER)

6. Click **OK** to close the ADD PWM dialog. The next step is configuring the frequencies.
7. Enter the desired frequency for Clock A and Clock B (if installed). The HEC-HMI has 4 available PWM Channels. These channels are either controlled with Clock A or Clock B. This allows two different PWM frequencies.

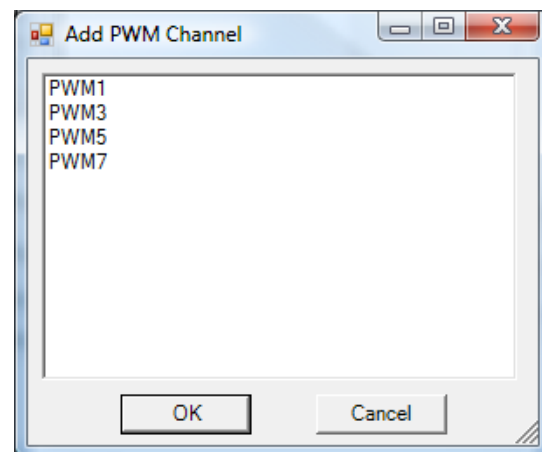

Figure 46 - Add PWM Channel Window

The Minimum and Maximum frequencies are displayed in the PWM Properties dialog. The frequency for Clock A and Clock B must be in this range. Refer to Figure 2.9.

Due to limitations of hardware, the Desired Frequency and Actual Frequency may vary. The Actual Frequency will be the closest attainable frequency to the entered Desired Frequency. The Minimum and Maximum frequencies are displayed.

8. Click **OK** to close the PWM Properties Window. Click **OK** to close the HEC-HMI Properties Window and click **OK** to close the Project Settings Window.

Refer to Figure 39 for PWM channel connections. Commutating diodes should be installed on all PWM output channels as shown for noise immunity. As the internal circuit is still a solid-state output, regardless whether configured as a digital output or a PWM output, all current limitations apply including the de-rating based on load and temperature. See the Digital Outputs part of this manual section and refer to Figure 40. If load current totals are to exceed 8 Amps, follow the recommendation for alternative power connections, see Figures 43 and 44. The same minimum load is required for PWM as for GPO operation.

With the Pulse Width Modulation Outputs configured in EZ LADDER, they can now be used in the ladder diagram project. The PWM channel(s) are controlled in the ladder diagram by the PWM and PWM_FREQ function blocks. For each PWM channel required, a PWM function block is required. Typically, PWM Outputs operate at a set frequency while the Duty Cycle is adjusted to vary the output. The Duty Cycle is a variable input to the PWM function block. In the event the frequency must be changed during operation, the PWM_FREQ function block is used. Refer to the EZ LADDER Toolkit User's Manual for more detail regarding function blocks and variables. See Figure 47.

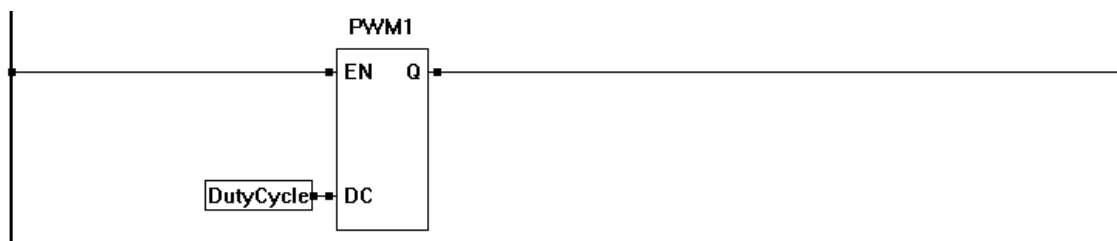

Figure 47- Using PWM in EZ LADDER

Relay Outputs

Of the HEC-HMI's six digital outputs, two are relay outputs. These relay outputs are configured as SPST, Normally open (dry contact). These relay digital outputs operate as an ON/OFF function using coils in the ladder diagram program.

These outputs are identified in the EZ LADDER Toolkit, on the HMI's terminal blocks and this manual as GPO4 - GPO5. These outputs are dry contacts; therefore they may be used in nearly any application with any voltage provided the maximum 2 Amp current rating is not exceeded per point.

The GPO4 and GPO5 relay outputs are located on TS14 and TS15. Connect the relay output contacts as shown in Figure 48.

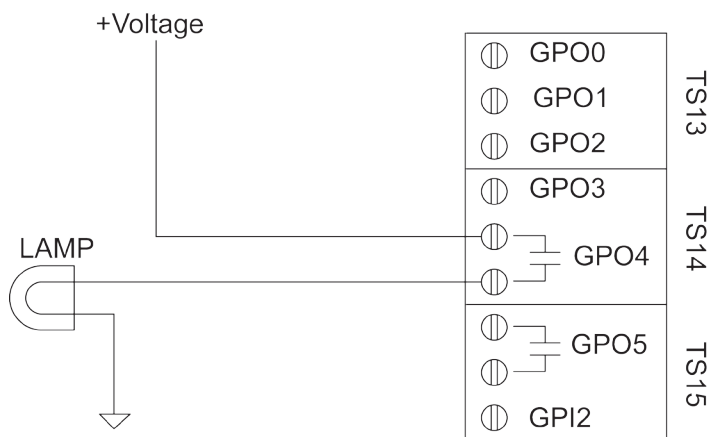

Figure 48- Relay Output Connections

To use GPO4 or GPO5 in a ladder diagram, place a coil in the ladder diagram, use the drop-down menu to select which Output to use (GPO4 or GPO5). Refer to Figure 49 for a typical Relay Output Circuit in EZ LADDER.

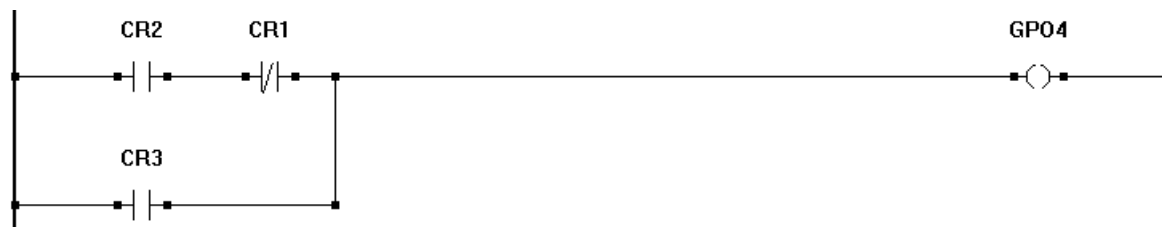



Figure 49- Using PWM in EZ LADDER

Analog I/O

This section will explain the HEC-HMI Controller's Analog I/O including:

Analog Inputs
Internal Current Feedback Analog Inputs
Analog Input Resolution

Analog Inputs Overview

 The HEC-HMI with Controller includes 7 usable analog inputs. These inputs are grouped into two categories; real world analog inputs and internal inputs. There are two real world inputs (AN0, AN1), 4 internal inputs (AN4, AN5, AN6, AN7) used for solid-state output current feedback and the one Input Power Monitor analog input (AN3) referred to in an earlier section. AN2 is only available when an Expansion Option is installed. AN is used to represent the analog inputs in the EZ LADDER Toolkit software. The HEC-HMI's analog inputs (terminals) are labeled using the same AN format.

These analog inputs are connected to via the internal terminal blocks provided. Each terminal can accept from 26 AWG to 16 AWG wire size. The analog inputs are located on TS9. See the HEC-HMI Basics section for a diagram of locations of the terminal block.

 The analog input resolution (for all analog inputs) is 15-bit, meaning the maximum scale for the analog inputs is 32767. Analog inputs are always INTEGER variables in EZ LADDER. If a REAL is required, the analog input will have to be converted using the REAL function block.

 A Moving Average function block (MAVG) is provided in EZ LADDER Toolkit. This function block allows for an easy to create moving average of an analog input.

Real World Analog Inputs

Of the Analog Inputs, the HEC-HMI with Controller provides 2 real world analog inputs. These two inputs are field selectable for 0-20mADC or 0-5VDC. They are identified on the terminal block and in the EZ LADDER Toolkit ladder diagram as AN0 and AN1. The AN0 and AN1 Integer variables are automatically created when the HEC-HMI target is selected in the Project Settings.

Each variable (AN0 - AN1) will represent the actual current reading on the analog input as an integer number (15-bit with a maximum scale of 32767). To use the analog input reading, place the appropriate analog input variable as an input to function blocks. See Figure 52.

Figure 51 shows the typical connections for using the analog inputs. Ideally, analog inputs should be wired using high quality shielded wire. To promote noise immunity, the shield should only be connected at one end.

AN0 and AN1 may be field configured individually for 0-5VDC or 0-20mADC. This is done by setting the internal configuration switches on SW1 and SW2. Refer to Figure 50 for setting the SW1 and SW2 analog input type.

 It is important configure the analog input type to match the actual analog input (0-5VDC or 0-20mADC). Failure to match these settings may result in damage to the HEC-HMI.

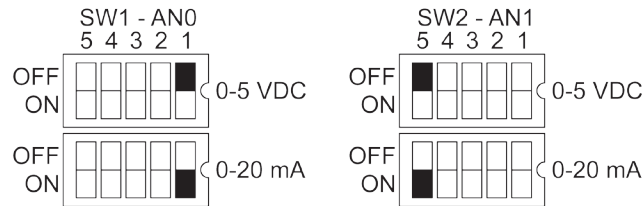

Figure 50 - Analog Input Configuration Switches

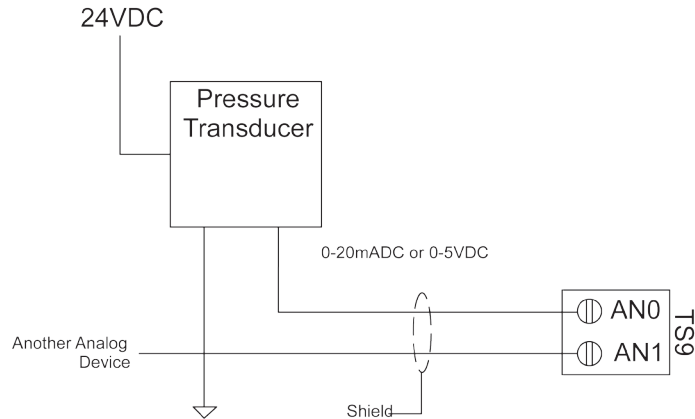

Figure 51 - Analog Input Connections Schematic

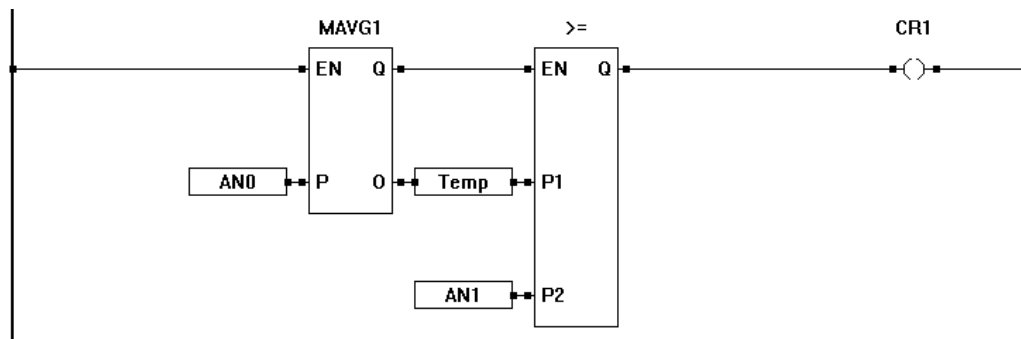

Figure 52 - Using Analog Inputs in EZ LADDER

Solid-State Output Current Feedback

The HEC-HMI provides current feedback for each Solid-State Output/PWM channel (GPO0 - GPO3). Each of these four outputs are internally monitored using analog inputs (AN4-AN7 respectively). This analog feedback represents the output current from 0 to 4 Amps.

As with all other analog inputs, these variables are created automatically when the HEC-HMI’s target is selected and configured. The resolution of these feedback analog input channels is dependent upon the model number of the HEC-HMI and will be equal to the real world analog inputs (AN0, AN1) including resolution, maximum scale, etc. In this case, 15-bit with a maximum scale of 32767.

These analog inputs may be used in combination with function blocks in circuits to calculate the actual output current on the PWM channel and then use this current in a control algorithm.

Commutating diodes must be installed on Solid-State Output channels when using the current feedback analog inputs. Failure to use commutating diodes will result in incorrect current feedback readings. See Figure 39.

Expansion Option 1

This section explains the expansion features included with the factory installed internal Option 1 Expansion board. This will include listed features, specifications and how to use the included features.

Option 1 includes these items:

- 1 Analog Input, Configurable as 0-20mADC, 0-5VDC or 0-10VDC. Resolution is 15-bit.
- 4 Solid-state digital outputs as GPO or PWM. Maximum 4ADC per pair.
- 1 Quadrature Counter. Supports A, B and Index.

Getting to Know Expansion Option 1

Expansion Option 1 is an internal factory installed expansion board. Please see below for an overview of connections and configuration switches and jumpers. To gain access to the internal connections and features, please see the HEC-HMI Assembly / Disassembly part of this manual section. For clarity, only the expansion features and connections are shown.

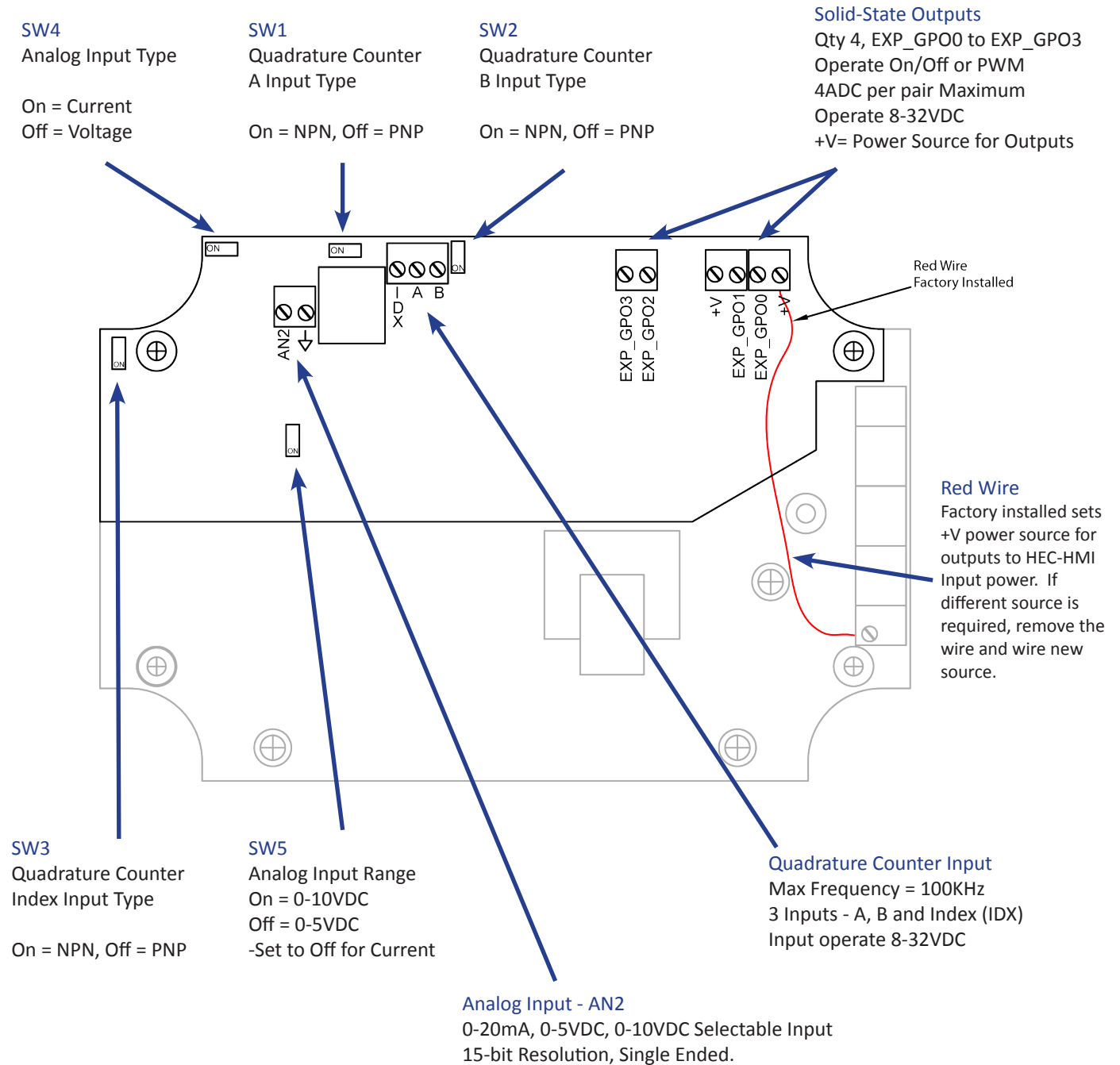

Analog Input

Expansion Option 1 provides one 15-bit resolution analog input. This analog input can be configured as 0-20mADC, 0-10VDC or 0-5VDC by on-board selection switches. See the Analog Input Circuit Schematic below for a representation of the actual analog input circuit on-board.

The analog input is configured using switches SW4 and SW5. When selecting Current 0-20mA, SW5 must be set to OFF.

Switch	ON	OFF
SW4	Current 0-20mA	Voltage
SW5	0-10VDC	0-5VDC

When selecting Current 0-20mA, SW5 must be set to OFF.

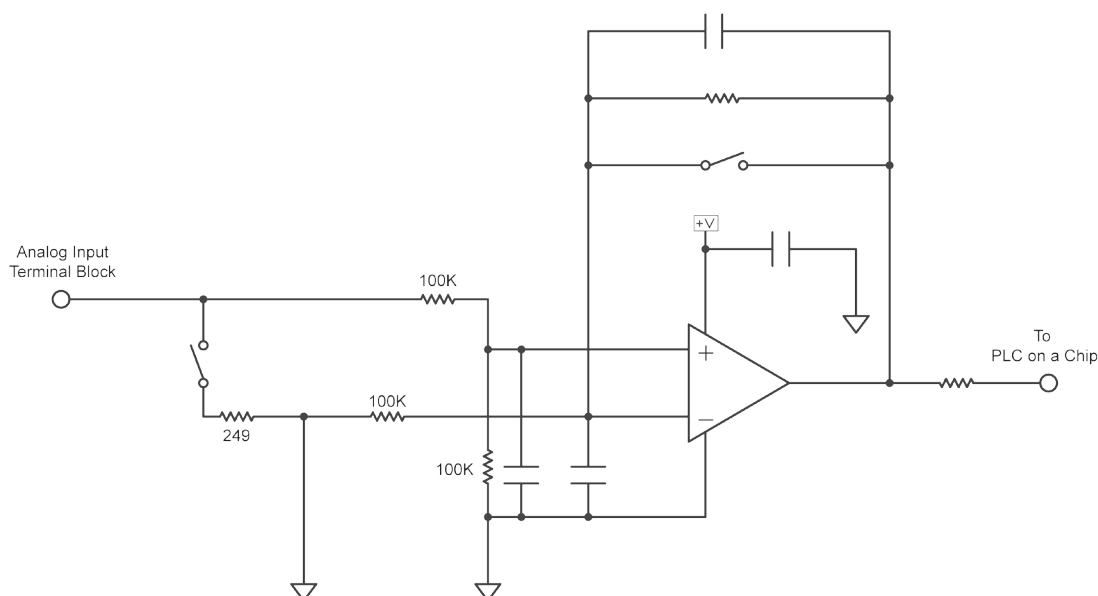

Analog Input Circuit Schematic

The analog input is preset to be read using the integer variable AN2. This variable is automatically created when the target is selected in the Project Settings.

For the HEC-HMI-C215x/C415x-E-R, the analog input is 15-bit, therefore, it's reading will be between 0 and 32767. The zero reading represents the minimum of what configuration is used (0V, 0mA) while 32767 represents the maximum of what configuration is used (5V, 10V or 20mA).

Using other functions in EZ LADDER, the analog input can be averaged, converted to a real and scaled as needed for any application.



Should an analog input reading appear to be only 1/2 or 2x what is expected, verify the switch settings are correct.

Digital Outputs Overview

The HEC-HMI with Expansion 1 provides 4 digital outputs. These two outputs are solid-state sourcing outputs with PWM capability. GPO is a general term used to represent **General Purpose Output**. These outputs may be used as PWM outputs utilizing the PWM function blocks in EZ LADDER Toolkit or GPO outputs (on/off) utilizing coils (boolean variables) in EZ LADDER Toolkit.

These digital outputs are connected to via the internal terminal blocks provided. Each terminal is rated for 10 Amps and can accept from 26 AWG to 16 AWG wire size. See the *Getting to Know Expansion Option 1* section for a diagram of locations of the terminal blocks.

 A red wire is factory installed from the main HEC-HMI circuit board to the expansion board +V terminal. This +V terminal sources the voltage for the outputs; therefore, with this wire installed, the input power to the HEC-HMI is sourced at this point and is the source for the outputs. If a different voltage source is required for these outputs, the wire must be removed and the +V terminal wired to an alternate (8-32VDC) voltage source with enough current to handle the output loads.

EXP_GPO0 - EXP_GPO3 also have a status return input. These inputs can be used to determine the status of the EXP-GPO output (open load, shorted, etc). These input variables (EXP_GPI2, EXP_GPI3, EXP_GPI4, EXP_GPI5 respectively) are automatically created when the target is selected. Consult factory for details regarding implementing the output status monitoring.

Solid-State Digital Outputs as General Purpose Outputs

The HEC-HMI Expansion Option 1 provides four digital outputs. All are solid-state; meaning they do not have mechanical moving parts (contacts).

 Each of the solid-state outputs may be used as either digital outputs that operate as an ON/OFF function using coils in the ladder diagram program or Pulse Width Modulation Outputs (PWM) using the PWM blocks in the ladder diagram. For general ON/OFF control needs, it is recommended that the GPO coils be used. When controlling devices such as valves, where you want to control the open/close amount in a closed loop system, Pulse Width Modulation (PWM) is recommended.

These outputs are identified in the EZ LADDER Toolkit and this manual as EXP_GPO0 - EXP_GPO3. These outputs are sourcing, therefore an energized output will source an output voltage equal to the voltage on the +V terminal.

 Each output can drive a load up to maximum current rating of 4 Amps Maximum per output pair (Refer to Output De-Rating diagram, for current and temperature ratings) and includes an automatic over-current shutdown safety. In the event an over current condition exists, the output will shut down. This shut down condition is reset when the output is turned off (set to false) in the ladder diagram. Loads are based on output pairs (EXP_GPO0 & EXP_GPO1, EXP_GPO2 & EXP_GPO3).

 Each output requires a minimum load to operate correctly. Depending upon the device connected to an output, a minimum load resistor may be required. If the output is ON or true regardless of the ladder diagram program, connect a 470Ω to 1KΩ load from the output to input power common.

As each digital output (EXP_GPO0 - EXP_GPO3) may be configured and used as a digital output or as a Pulse Width Modulation (PWM). Each of these four outputs may only be used as either digital output or PWM output only. For information on using digital outputs as PWM outputs, refer to the Pulse Width Modulation Outputs Section.



Commutating diodes should be installed on all output channels for noise immunity.

Refer to the Solid-State Output Connections Schematic for example output connections.

SOLID-STATE OUTPUT CONNECTIONS SCHEMATIC

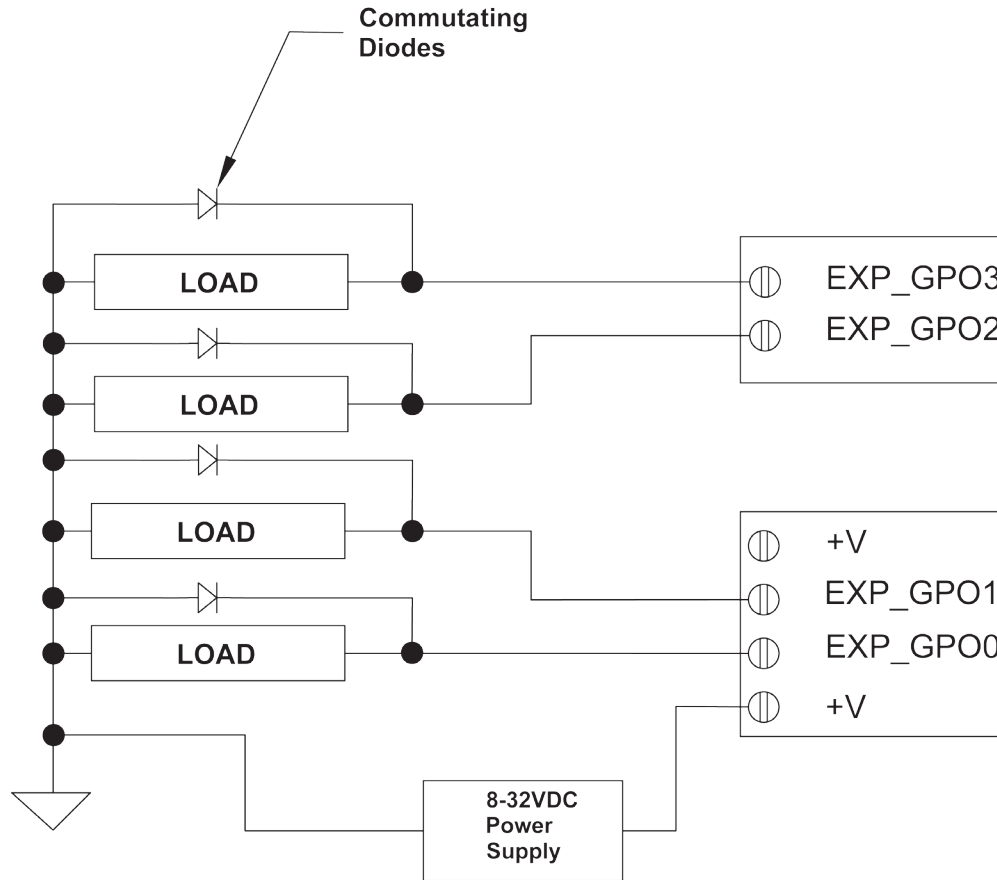

Expansion Option 1 Solid-State Outputs Connection Schematic - GPO or PWM

SOLID-STATE OUTPUT DE-RATING - LOAD & TEMPERATURE

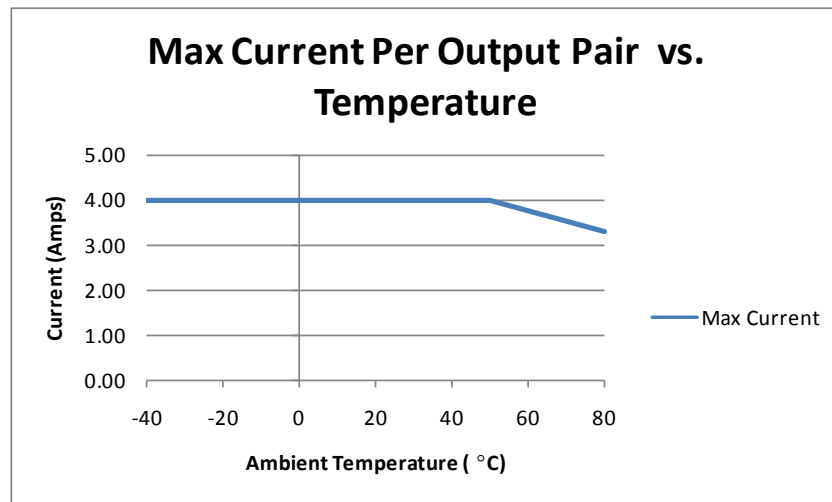

Solid-State Output De-Rating Curve

To control a digital output in a ladder diagram, place and connect the appropriate coil for your needs. The DIRECT COIL and INVERTED COIL functions are used to control digital outputs in the ladder diagram. When placing the coil, verify you select the correct output address (EXP_GPO0 - EXP_GPO3) from the provided drop-down menu. The EXP_GPO0 - EXP_GPO3 coils (boolean variables) are automatically created when the HEC-HMI model is selected in the Project Settings.



Using Digital Outputs in EZ LADDER

! When using the digital outputs on the HEC-HMI Expansion, wire size to the +V terminal and power source must be able to support the current required for the output loads.

Solid-State Digital Outputs as PWM

As previously noted, Expansion Option 1 includes 4 on-board digital outputs that may be configured individually and exclusively as either digital outputs or pulse width modulation outputs; therefore, each output may only be used as either digital output or PWM output. Pulse Width Modulation Outputs allow for a base frequency with an adjustable Duty Cycle. The base frequency may be changed in the ladder diagram also.

Before Pulse Width Modulation outputs may be used in the ladder diagram, the Pulse Width Modulation Properties must be configured in EZ LADDER Toolkit.

To Configure Pulse Width Modulation (PWM) Outputs in EZ LADDER Toolkit:

1. In EZ LADDER, from the File Menu at the top, click **PROJECT** then **SETTINGS**. This will open the Project Settings Window. The HEC-HMI was previously selected.
2. Click the **PROPERTIES** button. The HEC-HMI Properties Window will open.

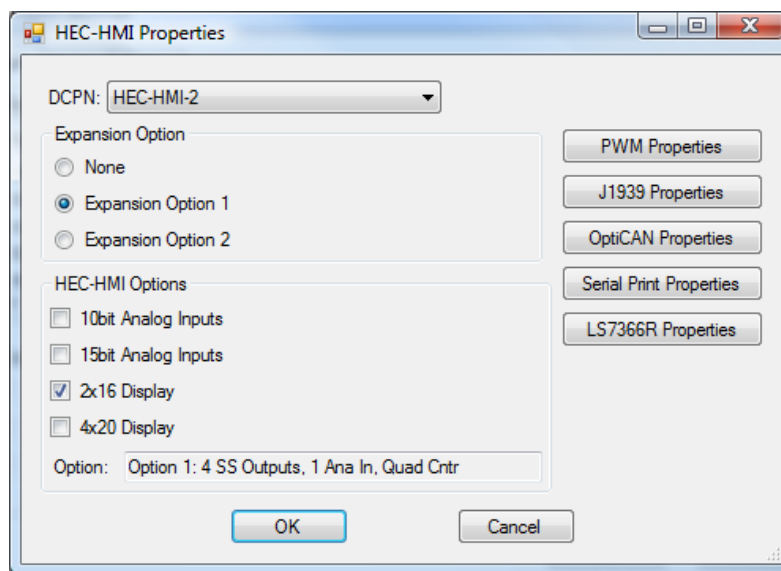

HEC-HMI Properties Window

- Click the **PWM PROPERTIES** button. The PWM Properties Window will open.

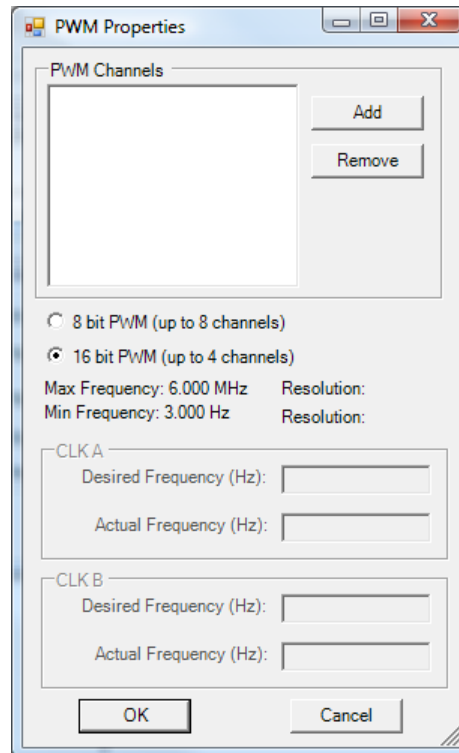

PWM Properties Window

- Select the resolution of the PWM channels (8 bit). Only 4 channels are supported regardless of resolution.
- Click the **ADD** button in the PWM Properties window.
- In the ADD PWM dialog, select the channels to install. To select multiple PWM channels, hold the CTRL key while clicking on the channel. Refer to Figure 46.

Only 4 PWM channels are supported, they are as follows:

Digital Output 0 (EXP_GPO0) is PWM 0 (in EZ LADDER)
 Digital Output 1 (EXP_GPO1) is PWM 2 (in EZ LADDER)
 Digital Output 2 (EXP_GPO2) is PWM 4 (in EZ LADDER)
 Digital Output 3 (EXP_GPO3) is PWM 6 (in EZ LADDER)

- Click **OK** to close the ADD PWM dialog. The next step is configuring the frequencies.
- Enter the desired frequency for Clock A and Clock B (if installed). The HEC-HMI has 4 available PWM Channels. These channels are either controlled with Clock A or Clock B. This allows two different PWM frequencies.

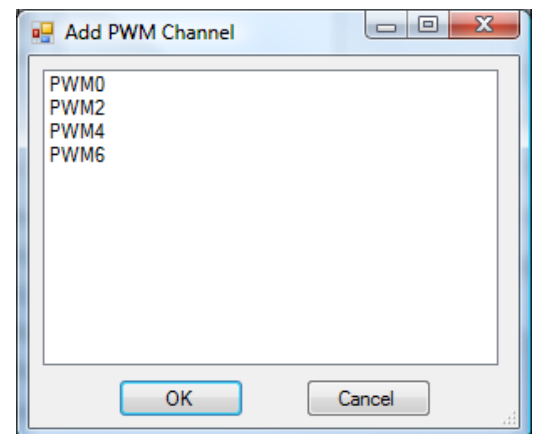

Add PWM Channel Window

The Minimum and Maximum frequencies are displayed in the PWM Properties dialog. The frequency for Clock A and Clock B must be in this range.

! Due to limitations of hardware, the Desired Frequency and Actual Frequency may vary. The Actual Frequency will be the closest attainable frequency to the entered Desired Frequency. The Minimum and Maximum frequencies are displayed.

8. Click **OK** to close the PWM Properties Window. Click **OK** to close the HEC-HMI Properties Window and click **OK** to close the Project Settings Window.

Refer to the diagram *Expansion Option 1 Solid-State Outputs Connections Schematic - GPO or PWM* for connections. Commutating diodes should be installed on all PWM output channels as shown for noise immunity. As the internal circuit is still a solid-state output, regardless whether configured as a digital output or a PWM output, all current limitations provided previously apply including the de-rating based on load and temperature.

With the Pulse Width Modulation Outputs configured in EZ LADDER, they can now be used in the ladder diagram project. The PWM channel(s) are controlled in the ladder diagram by the PWM and PWM_FREQ function blocks. For each PWM channel required, a PWM function block is required. Typically, PWM Outputs operate at a set frequency while the Duty Cycle is adjusted to vary the output. The Duty Cycle is a variable input to the PWM function block. In the event the frequency must be changed during operation, the PWM_FREQ function block is used. Refer to the EZ LADDER Toolkit User's Manual for more detail regarding function blocks and variables.

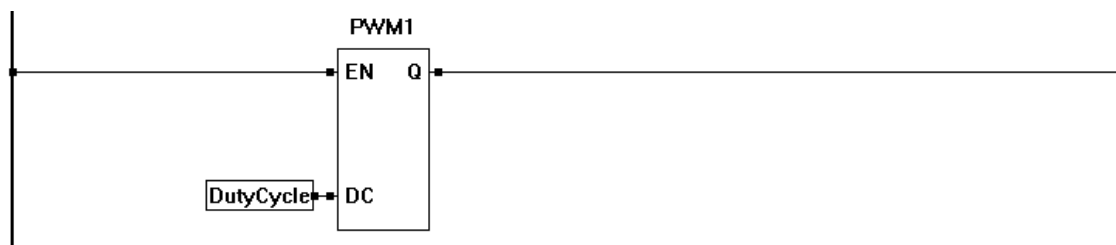

Using PWM in EZ LADDER

Quadrature Counter

The HEC-HMI Expansion Option 1 provides a quadrature counter input that supports A, B and Index. The quadrature counter input uses the SPI LS7366R counter integrated circuit. When the Expansion Option 1 is selected in the Project Settings, the LS7366R Quadrature counter is automatically installed in the project. The quadrature counter inputs will operate on 8-32VDC and support a maximum input frequency of 100KHz.



The LS7366R Quadrature Counter has multiple configuration settings that may need to be changed based on different applications. To configure the LS7366R operation, in EZ LADDER's Menu, select **PROJECT** then **SETTINGS**. The HEC-HMI target should still be selected. Click the **PROPERTIES** button. The HEC-HMI Properties window will open.

Click the **LS7366R PROPERTIES** button.

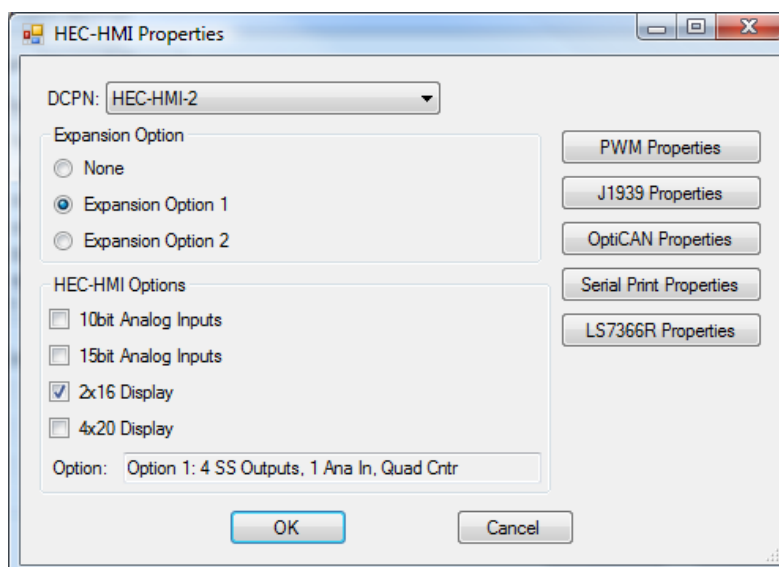

HEC-HMI Properties Window

The LS7366R Properties window will open. The LS7366R may be configured to run in several modes. Each mode has specific operation parameters and features that may be utilized in the ladder diagram project. These modes and parameters are configured in this window.

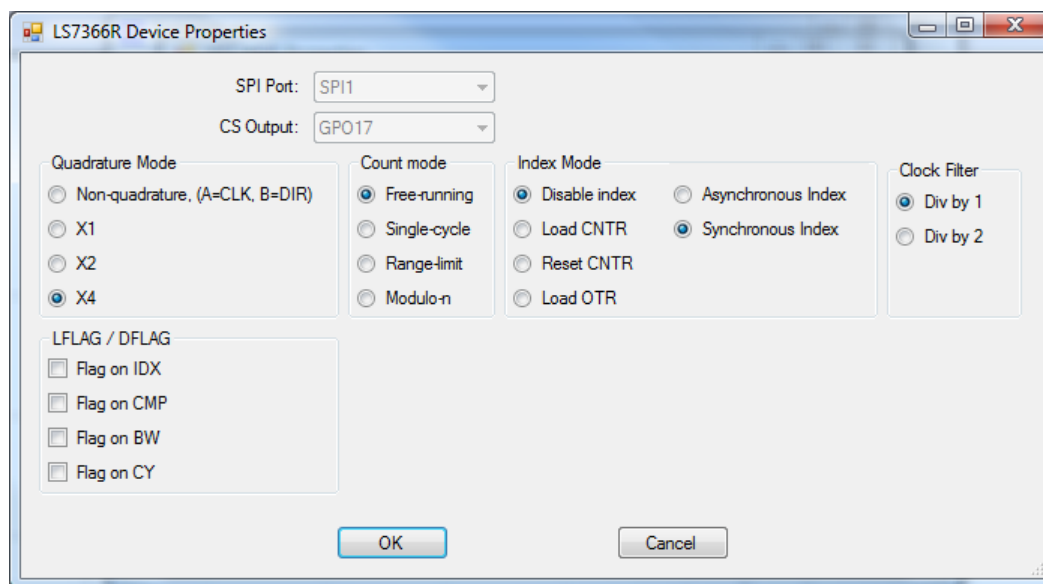

LS7366R Properties Window



The LS7366R operates using internal registers. There are three registers in the LS7366R. OTR, DTR and Actual Count. Per the design of the LS7366R, the actual count register can never be directly read or written to; therefore, the other registers must be used to read and write to the actual count. As an example, when the function block Read Count (RC) input is true, the actual count is copied to the OTR register and then the OTR registers is output at the function blocks count (CT) output. DTR is used to set the count value and may be used as a comparison (see LFLAG/DFLAG).

Quadrature Mode

Non-quadrature: Counter input B sets the direction of counting (increase or decrease), and a pulse on input A causes the counter to count by 1.

X1 quadrature: Counter operates in X1 quadrature mode.

X2 quadrature: Counter operates in X2 quadrature mode.

X4 quadrature: Counter operates in X4 quadrature mode.

Count Mode

Free-Running: Free running mode. Counter will wrap in either direction if maximum or minimum value is reached.

Single-cycle: Counter will count until maximum value is reached and then stop counting. Used with CY Flag. Counter must be reset to continue counting.

Range-limit: Counter will only count between zero and the value loaded in the DTR register.

Modulo-n: Actual count will equal number of pulses divided by value of the DTR register + 1.

Index Mode

Disable Index: Index input is disabled and will not cause any action on the actual count register.

Load CNTR: When the index input is active, the actual count register is loaded with the value of the DTR register. The DTR register is loaded using PD and LD on the function block.

Reset CNTR: When the Index input is active, the actual count register is reset to zero.

Load OTR: When the index input is active, the OTR register is loaded with the actual count register value. The OTR register is used to read the current count.

Asynchronous Index: In quadrature mode, if index is active, it is applied (acted on) regardless of its phase relationship to inputs A and B.

Synchronous Index: In quadrature mode, If index is active, it must meet the phase relationship of inputs A and B before it can be applied (acted on).

Clock Filter

Div by 1: Filter Frequency divided by 1. This is based on the input frequency of A and B inputs.

Div by 2: Filter Frequency divided by 2. This is based on the input frequency of A and B inputs.

LFLAG/DFLAG

Flag on IDX: When index is true, the LFLAG will set and latch, while DFLAG will be set only while the condition is maintained.

Flag on CMP: When actual count value = value of the DTR register, the LFLAG will set and latch, while DFLAG will be set only while the condition is maintained.

Flag on BW: When enabled, when counter wraps from zero to maximum, the LFLAG will set and latch, while DFLAG will be set only while the condition is maintained.

Flag on CY: When enabled, when counter wraps from maximum to zero, the LFLAG will set and latch, while DFLAG will be set only while the condition is maintained.

The DFLAG is read using EXP_GPI0 in EZ LADDER while LFLAG is read using EXP_GPI1 in EZ LADDER.

LS7366 Function Block (EZ LADDER software)

In addition to the hardware inputs that control the LS7366R, the CNTR_LS7366R function block is used in EZ LADDER to read the count, reset the count and control the registers.

EN: Function block enable (Boolean). When true, the function block is enabled.

RC: Read Count Input (Boolean). When true, the actual count is internally copied to OTR and then OTR is output at the count output (CT). When false, the OTR is output at the count output (CT) without copying the actual count.

LD: Load DTR input (Boolean). When true, the DTR register is loaded with the value of the variable connected to the PD input. When using LC and LD, LC has a higher priority and will execute first before LD.

LC: Load Counter input (Boolean). When true, the value of PC is loaded into the DTR register and then the DTR register is copied to the actual count. When using LC and LD, LC has a higher priority and will execute first before LD.

PD: Value (Integer) to be loaded into DTR when LD input is true.

PC: Value (Integer) to be loaded into DTR and then actual count when LC is true.

CE: Output (Boolean) is true when the function block is enabled and no errors are present.

DR: Direction output (Boolean). Identifies the current count direction (0 or 1).

ST: Status output (Integer). The output provides a numeric representation of the status of the LS7366R current function. Consult factory if more information is required.

CT: Current Count (Integer).

ITR_LS7366I

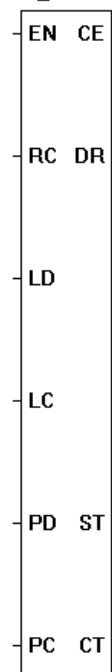
**Optional Counter Hardware Configurations**

There are three single switches on the HMI Expansion Option 1 for setting the counter input channel types. These switches determine whether the A, B and Index inputs accept signals from NPN or PNP devices. They are SW1 (Channel A), SW2 (Channel B) and SW3 (Index). When a switch is OFF, the input will be configured for PNP devices and when a switch is ON, the input will be configured for NPN devices. See the *Getting to Know Expansion Option 1* for locations of these switches.

When configured for NPN, pay close attention to the index input as depending upon how the counter is configured, the counter may be reset most of the time.

Expansion Option 2

This section explains the expansion features included with the factory installed internal Option 2 Expansion board. This will include listed features, specifications and how to use the included features.

Option 2 includes these items:

- 1 Analog Input, Configurable as 0-20mADC, 0-5VDC or 0-10VDC. Resolution is 10-bit.
- 2 Solid-state digital outputs as GPO or PWM. Maximum 4ADC per pair.
- 1 Quadrature Counter. Supports A, B and Index.
- 2 Thermocouple Inputs, Type K
- 2 DAC Outputs, Configurable as 0-20mADC or 0-10VDC

Getting to Know Expansion Option 2

Expansion Option 2 is an internal factory installed expansion board. Please see below for an overview of connections and configuration switches and jumpers. To gain access to the internal connections and features, please see the HEC-HMI Assembly / Disassembly part of this manual section. For clarity, only the expansion features and connections are shown.

- SW3**
Quadrature Counter
Index Input Type
On = NPN, Off = PNP
- SW4**
Analog Input Type
On = Current
Off = Voltage
- SW1**
Quadrature Counter
A Input Type
On = NPN, Off = PNP
- SW2**
Quadrature Counter
B Input Type
On = NPN, Off = PNP
- Solid-State Outputs**
Qty 2, EXP_GPO, EXP_GPO1
Operate On/Off or PWM
4ADC per pair Maximum
Operate 8-32VDC
+V= Power Source for Outputs

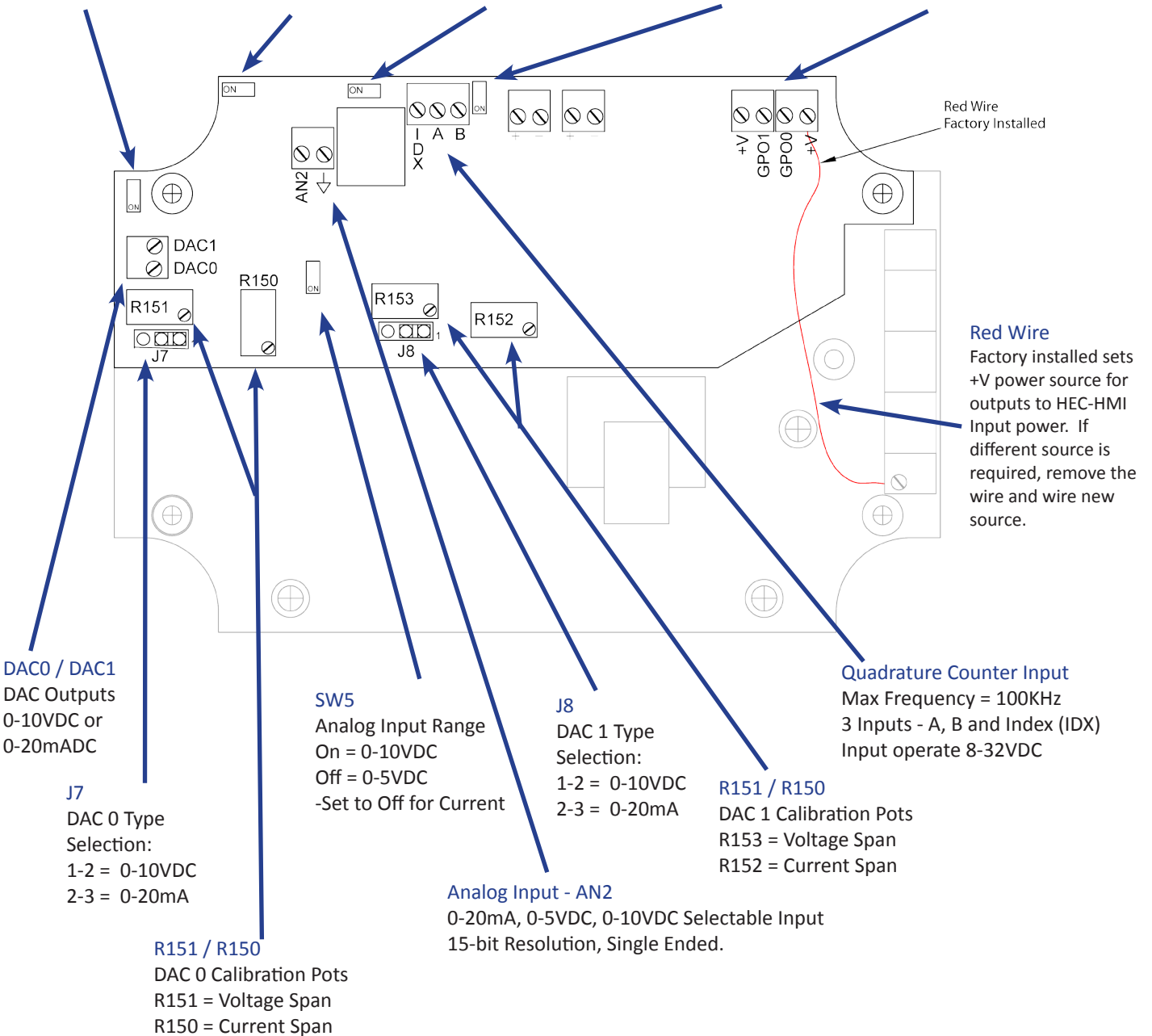

Analog Input

Expansion Option 2 provides one 15-bit resolution analog input. This analog input can be configured as 0-20mADC, 0-10VDC or 0-5VDC by on-board selection switches. See the Analog Input Circuit Schematic below for a representation of the actual analog input circuit on-board.

The analog input is configured using switches SW4 and SW5. When selecting Current 0-20mA, SW5 must be set to OFF.

Switch	ON	OFF
SW4	Current 0-20mA	Voltage
SW5	0-10VDC	0-5VDC

When selecting Current 0-20mA, SW5 must be set to OFF.

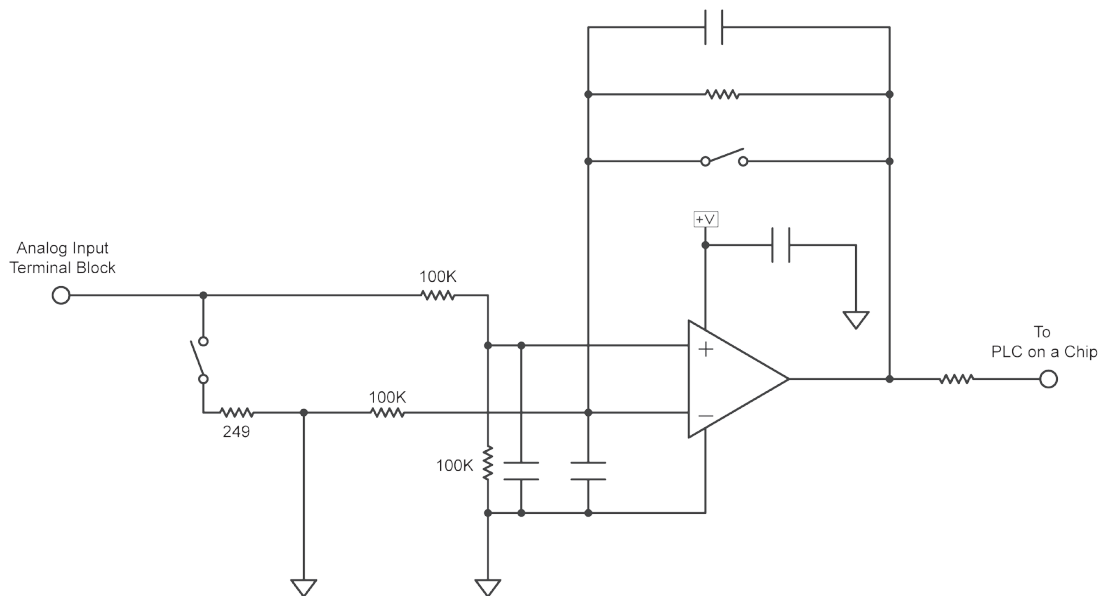

Analog Input Circuit Schematic

The analog input is preset to be read using the integer variable AN2. This variable is automatically created when the target is selected in the Project Settings.

For the HEC-HMI-C215x/C415x-E-R, the analog input is 15-bit, therefore, it's reading will be between 0 and 32767. The zero reading represents the minimum of what configuration is used (0V, 0mA) while 32767 represents the maximum of what configuration is used (5V, 10V or 20mA).

Using other functions in EZ LADDER, the analog input can be averaged, converted to a real and scaled as needed for any application.

 Should an analog input reading appear to be only 1/2 or 2x what is expected, verify the switch settings are correct.

Digital Outputs Overview

The HEC-HMI with Expansion 2 provides 2 digital outputs. These two outputs are solid-state sourcing outputs with PWM capability. GPO is a general term used to represent **General Purpose Output**. These outputs may be used as PWM outputs utilizing the PWM function blocks in EZ LADDER Toolkit or GPO outputs (on/off) utilizing coils (boolean variables) in EZ LADDER Toolkit.

These digital outputs are connected to via the internal terminal blocks provided. Each terminal is rated for 10 Amps and can accept from 26 AWG to 16 AWG wire size. See the *Getting to Know Expansion Option 2* section for a diagram of locations of the terminal blocks.

 A red wire is factory installed from the main HEC-HMI circuit board to the expansion board +V terminal. This +V terminal sources the voltage for the outputs; therefore, with this wire installed, the input power to the HEC-HMI is sourced at this point and is the source for the outputs. If a different voltage source is required for these outputs, the wire must be removed and the +V terminal wired to an alternate (8-32VDC) voltage source with enough current to handle the output loads.

EXP_GPO0 - EXP_GPO1 also have a status return input. These inputs can be used to determine the status of the EXP-GPO output (open load, shorted, etc). These input variables (EXP_GPI2, EXP_GPI3 respectively) are automatically created when the target is selected. Consult factory for details regarding implementing the output status monitoring.

Solid-State Digital Outputs as General Purpose Outputs

The HEC-HMI Expansion Option 2 provides four digital outputs. All are solid-state; meaning they do not have mechanical moving parts (contacts).

 Each of the solid-state outputs may be used as either digital outputs that operate as an ON/OFF function using coils in the ladder diagram program or Pulse Width Modulation Outputs (PWM) using the PWM blocks in the ladder diagram. For general ON/OFF control needs, it is recommended that the GPO coils be used. When controlling devices such as valves, where you want to control the open/close amount in a closed loop system, Pulse Width Modulation (PWM) is recommended.

These outputs are identified in the EZ LADDER Toolkit and this manual as EXP_GPO0 - EXP_GPO1. These outputs are sourcing, therefore an energized output will source an output voltage equal to the voltage on the +V terminal.

 Each output can drive a load up to maximum current rating of 4 Amps Maximum per output pair (Refer to Output De-Rating diagram, for current and temperature ratings) and includes an automatic over-current shutdown safety. In the event an over current condition exists, the output will shut down. This shut down condition is reset when the output is turned off (set to false) in the ladder diagram. Loads are based on output pairs (EXP_GPO0 & EXP_GPO1).

 Each output requires a minimum load to operate correctly. Depending upon the device connected to an output, a minimum load resistor may be required. If the output is ON or true regardless of the ladder diagram program, connect a 470Ω to 1KΩ load from the output to input power common.

As each digital output (EXP_GPO0 - EXP_GPO1) may be configured and used as a digital output or as a Pulse Width Modulation (PWM). Each of these four outputs may only be used as either digital output or PWM output only. For information on using digital outputs as PWM outputs, refer to the Pulse Width Modulation Outputs Section.



Commutating diodes should be installed on all output channels for noise immunity.

Refer to the Solid-State Output Connections Schematic for example output connections.

SOLID-STATE OUTPUT CONNECTIONS SCHEMATIC

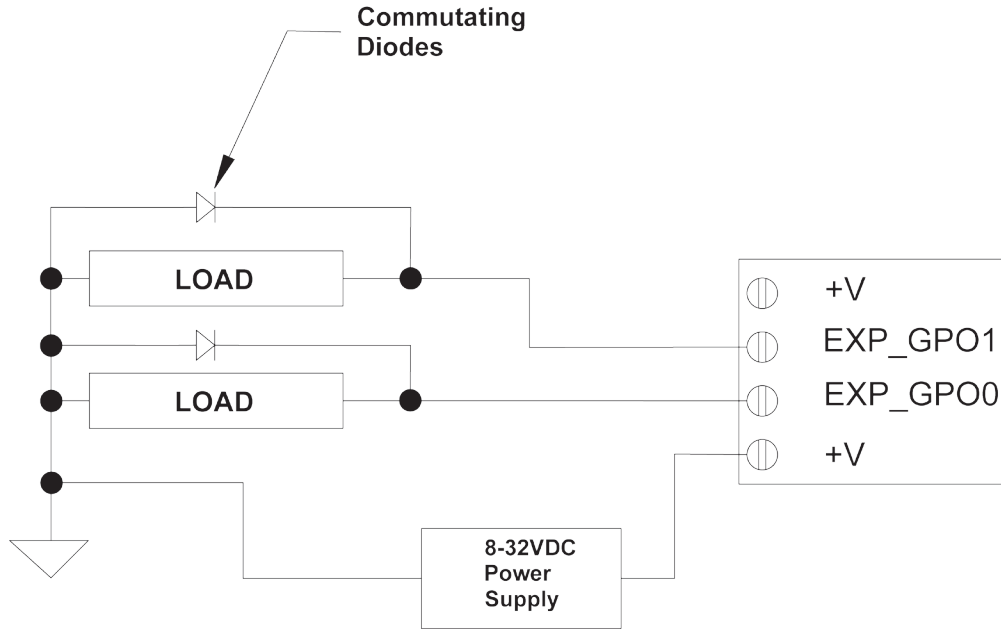

Expansion Option 2 Solid-State Outputs Connection Schematic - GPO or PWM

SOLID-STATE OUTPUT DE-RATING - LOAD & TEMPERATURE

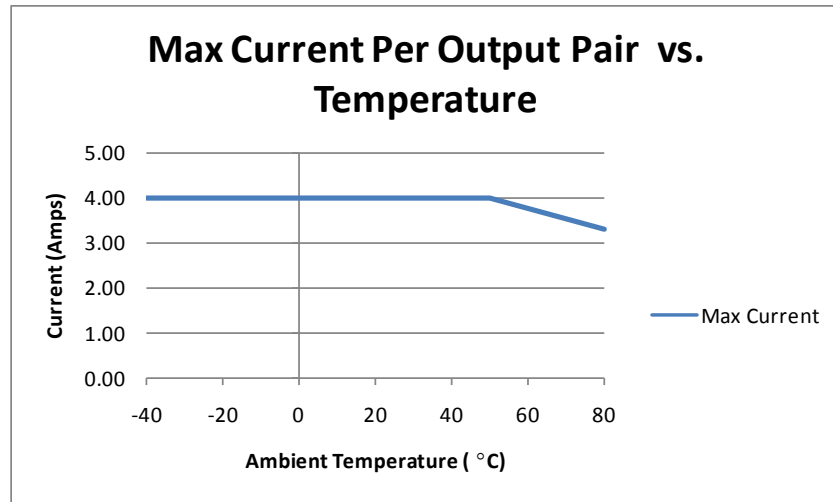

Solid-State Output De-Rating Curve

To control a digital output in a ladder diagram, place and connect the appropriate coil for your needs. The DIRECT COIL and INVERT-ED COIL functions are used to control digital outputs in the ladder diagram. When placing the coil, verify you select the correct output address (EXP_GPO0 - EXP_GPO1) from the provided drop-down menu. The EXP_GPO0 - EXP_GPO1 coils (boolean variables are automatically created when the HEC-HMI model is selected in the Project Settings.



Using Digital Outputs in EZ LADDER

When using the digital outputs on the HEC-HMI Expansion, wire size to the +V terminal and power source must be able to support the current required for the output loads.

Solid-State Digital Outputs as PWM

As previously noted, Expansion Option 2 includes 3 on-board digital outputs that may be configured individually and exclusively as either digital outputs or pulse width modulation outputs; therefore, each output may only be used as either digital output or PWM output. Pulse Width Modulation Outputs allow for a base frequency with an adjustable Duty Cycle. The base frequency may be changed in the ladder diagram also.

Before Pulse Width Modulation outputs may be used in the ladder diagram, the Pulse Width Modulation Properties must be configured in EZ LADDER Toolkit.

To Configure Pulse Width Modulation (PWM) Outputs in EZ LADDER Toolkit:

1. In EZ LADDER, from the File Menu at the top, click **PROJECT** then **SETTINGS**. This will open the Project Settings Window. The HEC-HMI was previously selected.
2. Click the **PROPERTIES** button. The HEC-HMI Properties Window will open.

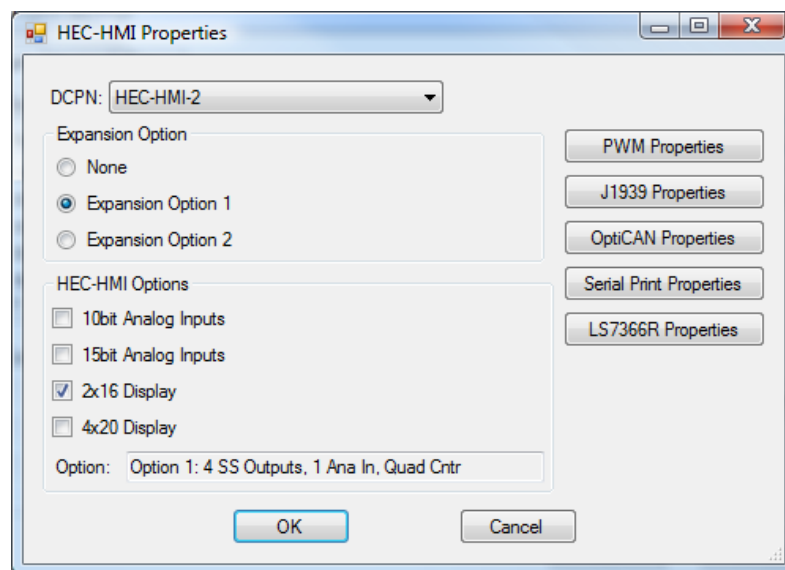

HEC-HMI Properties Window

- Click the **PWM PROPERTIES** button. The PWM Properties Window will open.

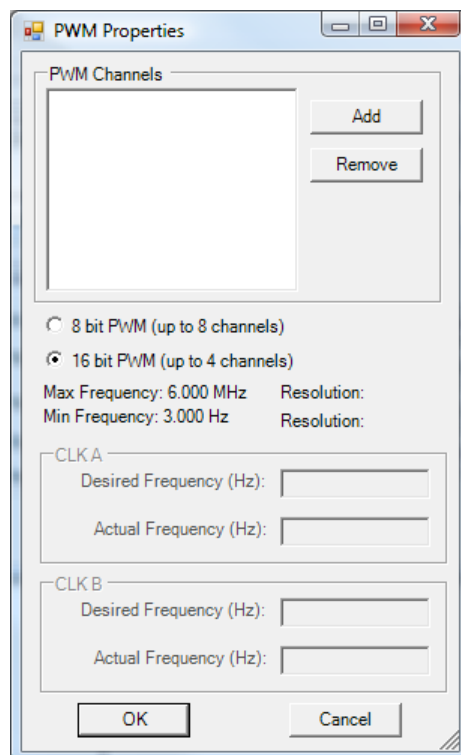

PWM Properties Window

- Select the resolution of the PWM channels (8 bit). Only 2 channels are supported regardless of resolution.
- Click the **ADD** button in the PWM Properties window.
- In the ADD PWM dialog, select the channels to install. To select multiple PWM channels, hold the CTRL key while clicking on the channel. Refer to Figure 46.

Only 2 PWM channels are supported, they are as follows:

Digital Output 0 (EXP_GPO0) is PWM 0 (in EZ LADDER)
 Digital Output 1 (EXP_GPO1) is PWM 2 (in EZ LADDER)

- Click **OK** to close the ADD PWM dialog. The next step is configuring the frequencies.
- Enter the desired frequency for Clock A and Clock B (if installed). The HEC-HMI has 2 available PWM Channels. These channels are either controlled with Clock A or Clock B. This allows two different PWM frequencies.

The Minimum and Maximum frequencies are displayed in the PWM Properties dialog. The frequency for Clock A and Clock B must be in this range.



Due to limitations of hardware, the Desired Frequency and Actual Frequency may vary. The Actual Frequency will be the closest attainable frequency to the entered Desired Frequency. The Minimum and Maximum frequencies are displayed.

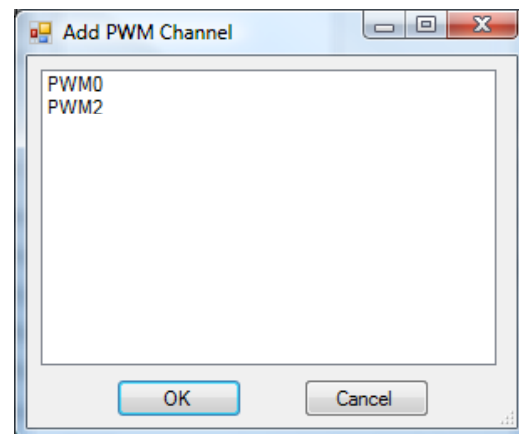

Add PWM Channel Window

8. Click **OK** to close the PWM Properties Window. Click **OK** to close the HEC-HMI Properties Window and click **OK** to close the Project Settings Window.

Refer to the diagram *Expansion Option 2 Solid-State Outputs Connections Schematic - GPO or PWM* for connections. Commutating diodes should be installed on all PWM output channels as shown for noise immunity. As the internal circuit is still a solid-state output, regardless whether configured as a digital output or a PWM output, all current limitations provided previously apply including the de-rating based on load and temperature.

With the Pulse Width Modulation Outputs configured in EZ LADDER, they can now be used in the ladder diagram project. The PWM channel(s) are controlled in the ladder diagram by the PWM and PWM_FREQ function blocks. For each PWM channel required, a PWM function block is required. Typically, PWM Outputs operate at a set frequency while the Duty Cycle is adjusted to vary the output. The Duty Cycle is a variable input to the PWM function block. In the event the frequency must be changed during operation, the PWM_FREQ function block is used. Refer to the EZ LADDER Toolkit User's Manual for more detail regarding function blocks and variables.

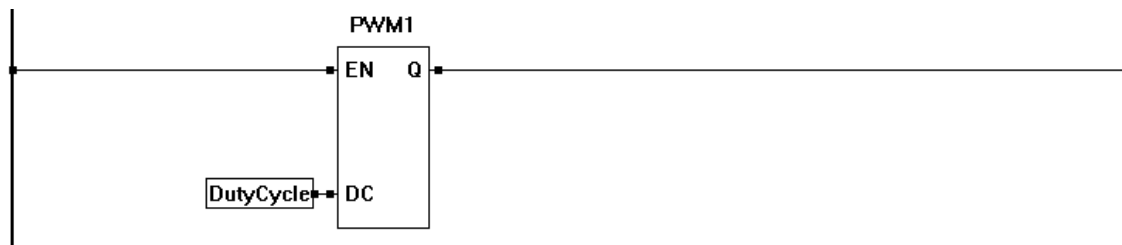

Using PWM in EZ LADDER

Quadrature Counter

The HEC-HMI Expansion Option 2 provides a quadrature counter input that supports A, B and Index. The quadrature counter input uses the SPI LS7366R counter integrated circuit. When the Expansion Option 2 is selected in the Project Settings, the LS7366R Quadrature counter is automatically installed in the project. The quadrature counter inputs will operate on 8-32VDC and support a maximum input frequency of 100KHz.



The LS7366R Quadrature Counter has multiple configuration settings that may need to be changed based on different applications. To configure the LS7366R operation, in EZ LADDER's Menu, select **PROJECT** then **SETTINGS**. The HEC-HMI target should still be selected. Click the **PROPERTIES** button. The HEC-HMI Properties window will open.

Click the **LS7366R PROPERTIES** button.

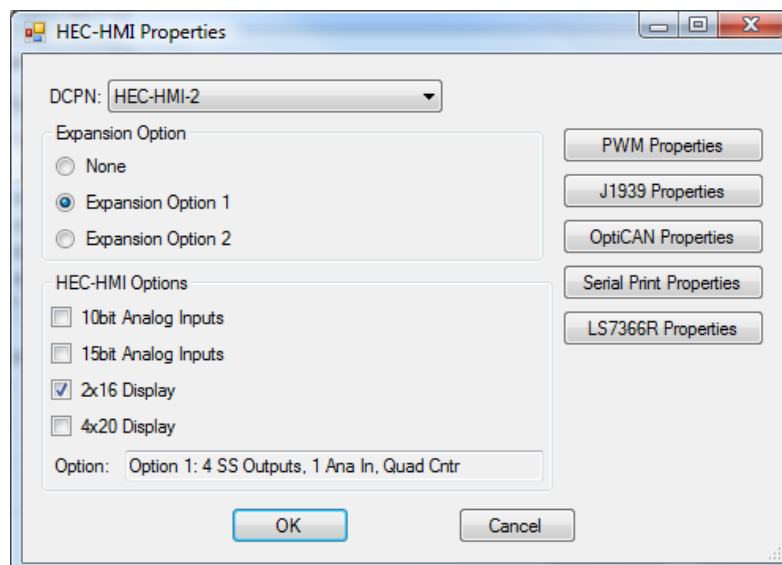

HEC-HMI Properties Window

The LS7366R Properties window will open. The LS7366R may be configured to run in several modes. Each mode has specific operation parameters and features that may be utilized in the ladder diagram project. These modes and parameters are configured in this window.

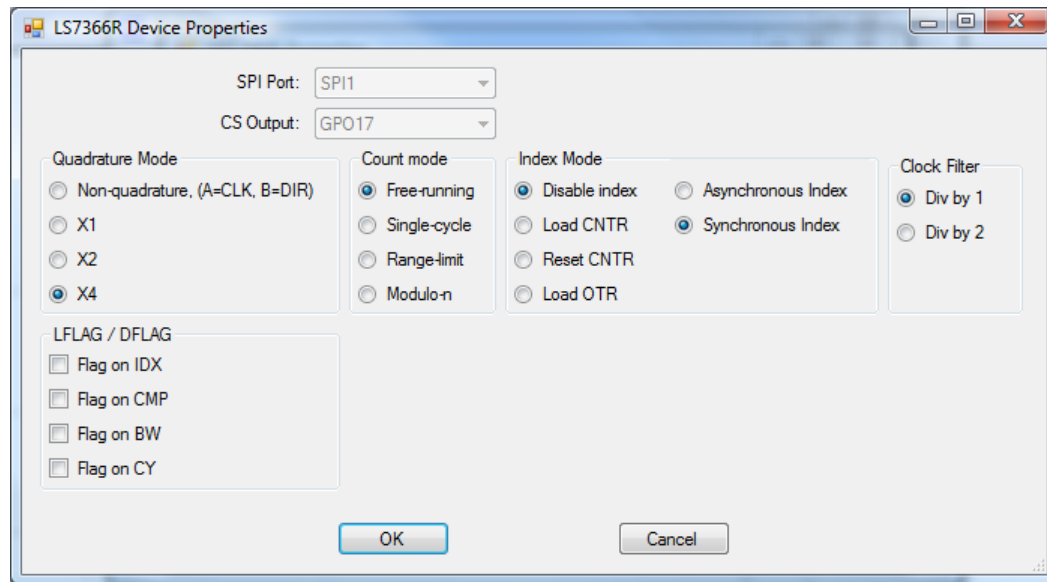

LS7366R Properties Window



The LS7366R operates using internal registers. There are three registers in the LS7366R. OTR, DTR and Actual Count. Per the design of the LS7366R, the actual count register can never be directly read or written to; therefore, the other registers must be used to read and write to the actual count. As an example, when the function block Read Count (RC) input is true, the actual count is copied to the OTR register and then the OTR registers is output at the function blocks count (CT) output. DTR is used to set the count value and may be used as a comparison (see LFLAG/DFLAG).

Quadrature Mode

Non-quadrature: Counter input B sets the direction of counting (increase or decrease), and a pulse on input A causes the counter to count by 1.

X1 quadrature: Counter operates in X1 quadrature mode.

X2 quadrature: Counter operates in X2 quadrature mode.

X4 quadrature: Counter operates in X4 quadrature mode.

Count Mode

Free-Running: Free running mode. Counter will wrap in either direction if maximum or minimum value is reached.

Single-cycle: Counter will count until maximum value is reached and then stop counting. Used with CY Flag. Counter must be reset to continue counting.

Range-limit: Counter will only count between zero and the value loaded in the DTR register.

Modulo-n: Actual count will equal number of pulses divided by value of the DTR register + 1.

Index Mode

Disable Index: Index input is disabled and will not cause any action on the actual count register.

Load CNTR: When the index input is active, the actual count register is loaded with the value of the DTR register. The DTR register is loaded using PD and LD on the function block.

Reset CNTR: When the Index input is active, the actual count register is reset to zero.

Load OTR: When the index input is active, the OTR register is loaded with the actual count register value. The OTR register is used to read the current count.

Asynchronous Index: In quadrature mode, if index is active, it is applied (acted on) regardless of its phase relationship to inputs A and B.

Synchronous Index: In quadrature mode, If index is active, it must meet the phase relationship of inputs A and B before it can be applied (acted on).

Clock Filter

Div by 1: Filter Frequency divided by 1. This is based on the input frequency of A and B inputs.

Div by 2: Filter Frequency divided by 2. This is based on the input frequency of A and B inputs.

LFLAG/DFLAG

Flag on IDX: When index is true, the LFLAG will set and latch, while DFLAG will be set only while the condition is maintained.

Flag on CMP: When actual count value = value of the DTR register, the LFLAG will set and latch, while DFLAG will be set only while the condition is maintained.

Flag on BW: When enabled, when counter wraps from zero to maximum, the LFLAG will set and latch, while DFLAG will be set only while the condition is maintained.

Flag on CY: When enabled, when counter wraps from maximum to zero, the LFLAG will set and latch, while DFLAG will be set only while the condition is maintained.

The DFLAG is read using EXP_GPI0 in EZ LADDER while LFLAG is read using EXP_GPI1 in EZ LADDER.

LS7366 Function Block (EZ LADDER software)

In addition to the hardware inputs that control the LS7366R, the CNTR_LS7366R function block is used in EZ LADDER to read the count, reset the count and control the registers.

EN: Function block enable (Boolean). When true, the function block is enabled.

RC: Read Count Input (Boolean). When true, the actual count is internally copied to OTR and then OTR is output at the count output (CT). When false, the OTR is output at the count output (CT) without copying the actual count.

LD: Load DTR input (Boolean). When true, the DTR register is loaded with the value of the variable connected to the PD input. When using LC and LD, LC has a higher priority and will execute first before LD.

LC: Load Counter input (Boolean). When true, the value of PC is loaded into the DTR register and then the DTR register is copied to the actual count. When using LC and LD, LC has a higher priority and will execute first before LD.

PD: Value (Integer) to be loaded into DTR when LD input is true.

PC: Value (Integer) to be loaded into DTR and then actual count when LC is true.

CE: Output (Boolean) is true when the function block is enabled and no errors are present.

DR: Direction output (Boolean). Identifies the current count direction (0 or 1).

ST: Status output (Integer). The output provides a numeric representation of the status of the LS7366R current function. Consult factory if more information is required.

CT: Current Count (Integer).

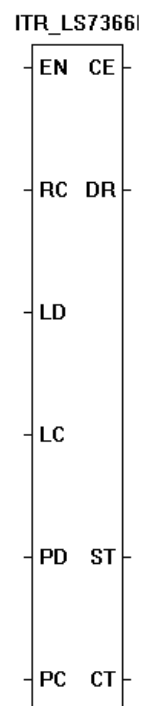
**Optional Counter Hardware Configurations**

There are three single switches on the HMI Expansion Option 2 for setting the counter input channel types. These switches determine whether the A, B and Index inputs accept signals from NPN or PNP devices. They are SW1 (Channel A), SW2 (Channel B) and SW3 (Index). When a switch is OFF, the input will be configured for PNP devices and when a switch is ON, the input will be configured for NPN devices. See the *Getting to Know Expansion Option 2* for locations of these switches.

When configured for NPN, pay close attention to the index input as depending upon how the counter is configured, the counter may be reset most of the time.

DAC Outputs

The HEC-HMI Expansion Option 2 provides 2 Digital to Analog Outputs (DAC). The DAC outputs (DAC 0 and DAC 1) may be configured for either 0-10VDC or 0-20mADC. DAC 0 is configured using J7 while DAC 1 is configured using J8. The DAC outputs are connected to the DAC terminal block. See the *Getting to Know Expansion Option 2* for locations of these jumpers and connections.

DAC Calibration

If calibration is required, calibration (SPAN) potentiometers are provided. For DAC 0 configured for 0-10VDC, R151 adjusts the span of the output. For DAC 0 configured for 0-20mADC, R150 adjusts the span of the output. For DAC 1 configured for 0-10VDC, R153 adjusts the span of the output. For DAC 1 configured for 0-20mADC, R153 adjusts the span of the output.

Controlling DAC Outputs in EZ LADDER

The DAC outputs are controlled in EZ LADDER by two integer variables (DAC0, DAC1). These variables are automatically created when Expansion Option 2 is selected in the Project Settings.



As values change for these variables in the ladder diagram, the actual corresponding DAC output will adjust automatically. The supported variable integer range is 0 to 2048, where 0 = 0VDC or 0mADC and 2048 = 10VDC or 20mADC.

Thermocouple Inputs

The HEC-HMI Expansion Option 2 provides 2 thermocouple inputs - type K. These two inputs are connected via the provided terminal blocks. See the *Getting to Know Expansion Option 2* for location of these connections.



The negative (-) terminal of the TC1 and TC2 are not connected internally to ground or common.

The actual temperature for each channel is read in EZ LADDER using real variables TC1 and TC2. These variable represent the temperature read on each channel in degrees C (°C) or if an error occurs an specific number.

Thermocouple Detectable Errors:

Read Variable Value	Detected Error
-9996	Undetermined
-9997	Thermocouple shorted high (+V)
-9998	Thermocouple shorted low (Gnd)
-9999	Thermocouple open