

SOLVES-IT! HOUR METER APPLICATION MODULE

Revision 0 for Software Version 1.0.0.0



PLC on a Chip Patent 7,299,099

A larger format of this manual may be
found at <http://www.divebiss.com>



Smart Parts for Managing Automation

9778 Mt. Gilead Rd.
Fredericktown, OH 43019
Toll Free: 1-800-245-2327
Web: <http://www.divebiss.com>
Email: sales@divebiss.com

TABLE OF CONTENTS

Table of Contents	Page 1
Package Contents	Page 1
Getting Started	Page 2
How to Use this Manual	Page 2
SI-APPMOD-HourMeter Basics	Page 3
Get to Know the Module	Page 3
Module Mounting	Page 4
Module Input Power	Page 4
Module Operation	Page 5
User Interface	Page 5
Input Connections	Page 6
Output Connections	Page 6
Changing Setpoints	Page 7
Expandability / Customization	Page 8
Programmed from Factory Specifications	Page 8

WARNING!

The SI-APPMOD-HOURMETER, as with programmable controllers, must not be used alone in applications which would be hazardous to personnel in the event of failure of this device. Precautions must be taken by the user to provide mechanical and/or electrical safeguards external to this device. This device is **NOT APPROVED** for domestic or human medical use.

PACKAGE CONTENTS

Whats Included

Qty	Description	Part Number	Location
1	SI-200 with Software Pre-loaded	SI-200	In Box
1	SI-APPMOD-HOURMETER Manual	2008014.X	In Box
1	Din-rail Socket	115-105328	In Box
4	Commutating Diodes	111-101012	In Box

GETTING STARTED

This section explains how to read this manual and understand the symbols.

HOW TO USE THIS MANUAL

In this manual, the following conventions are used to distinguish elements of text:

BOLD	Denotes labeling, commands, and literal portions of syntax that must appear exactly as shown.
<i>italic</i>	Used for variables and placeholders that represent the type of text to be entered by the user.
SMALL CAPS	Used to show key sequences or actual buttons, such as OK, where the user clicks the OK button.

In addition, the following symbols appear periodically in the left margin to call the readers attention to specific details in the text:



Warns the reader of a potential danger or hazard that is associated with certain actions.



Appears when the text contains a tip that is especially helpful.



Indicates that the text contains information to which the reader should pay particularly close attention.

All Information and Specifications Subject to Change without Notice

MODULE BASICS

This section describes the SI-APPMOD-HourMeter Application Module including input/output assignments and an operational description.

GETTING TO KNOW THE MODULE

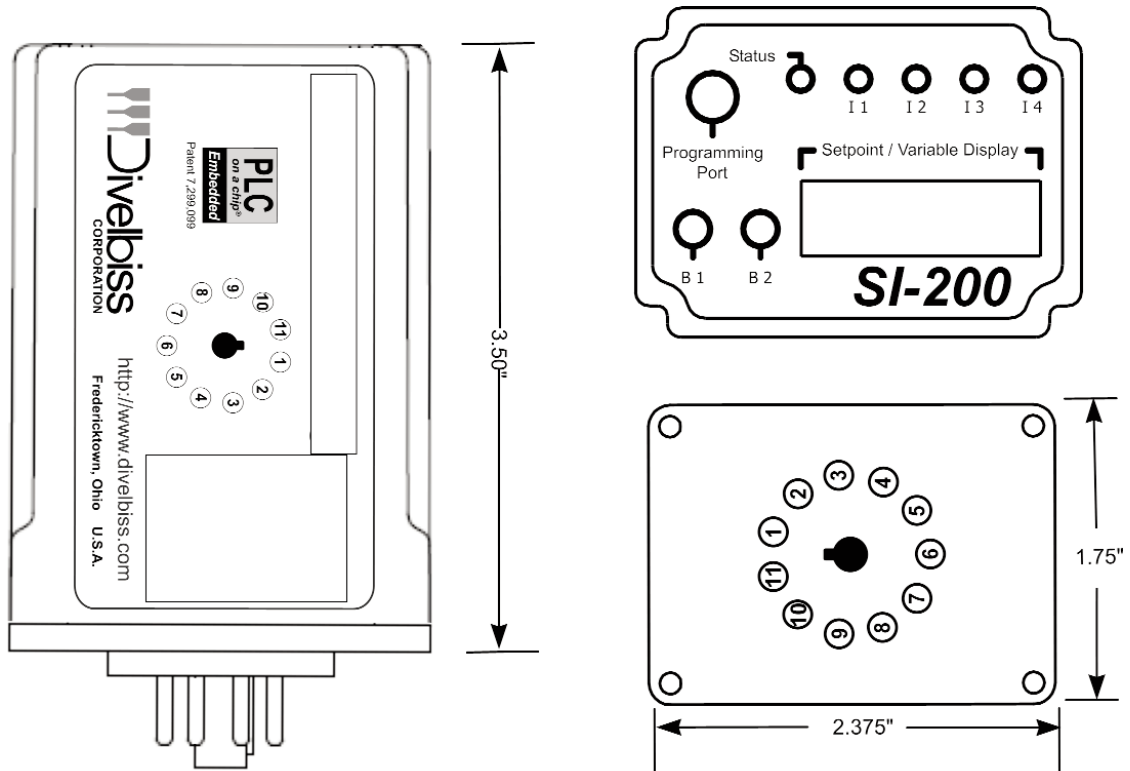

The module is connected to external devices via its included mounting socket.

Connector Pin out

Bottom View (Solves-It! Connector)

Pin 1	Setpoint 2 Output
Pin 2	Setpoint 1 Output
Pin 3	Hour Meter Reset Input
Pin 4	Hour Meter Overflow Alarm Reset Input
Pin 5	Input 2 - Not Used
Pin 6	Input 3 - Not Used
Pin 7	Earth Gnd
Pin 8	Input Power Common
Pin 9	10-24.5VDC Input Power
Pin 10	Output 4 - Not Used
Pin 11	Output 3 - Not Used

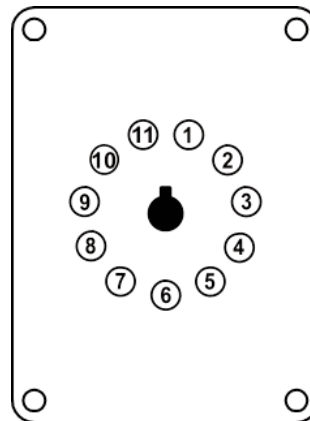

Figure 2.1 - Module Pin-Out

MODULE MOUNTING

The Module mounts to an industry standard 11-pin Octal relay socket. To mount the module, align with the socket and firmly push into position.

MODULE INPUT POWER

The module can be powered with 10-24.5VDC. The input power must be of sufficient supply to drive the module and the outputs (based on the load currents for each) Maximum current for the module is 150mADC and maximum load for each outputs is 300mADC. For the pre-programmed software, 2 outputs are used and may be on at a time. Exceeding a total output load of greater than 1ADC (more than 3 outputs at full load simultaneously) can damage the module.

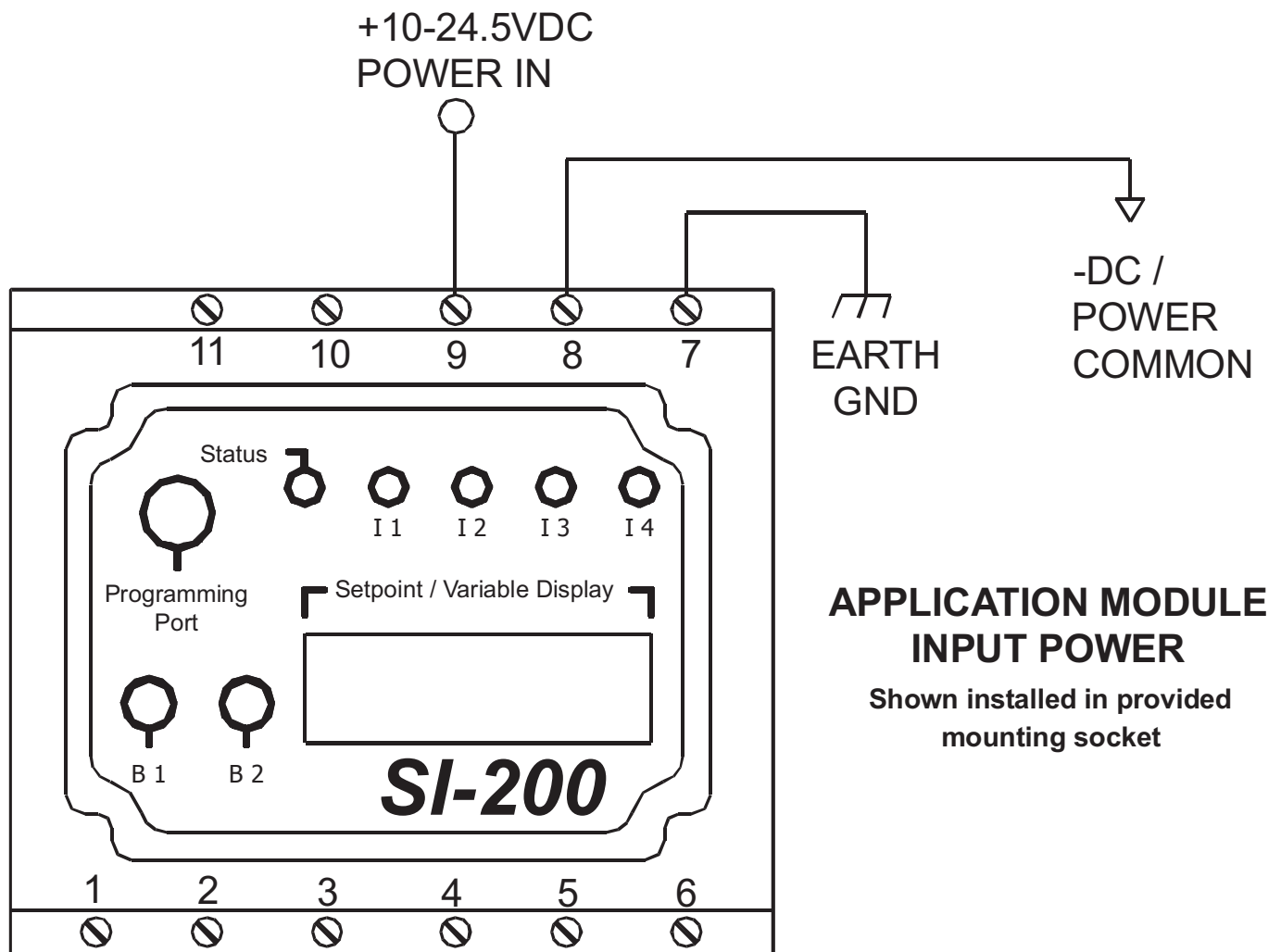

Figure 2.2 - Module Input Power Diagram

MODULE OPERATION

The SI-APPMOD-HourMeter operates as an on-power timer. For each second the module is powered, the hour meter will increment. While only hours are displayed, the module keeps time to a one-second resolution. Two individual setpoints and outputs are provided as alarm features. Each setpoint can be set from 0 to 9999 hours. When the hourmeter time reaches each setpoint, its output will energize.

The hourmeter will operate up to 9999 hours before overflowing and wrapping back to zero. If this should occur, I4 will flash indicating the hour meter has rolled over to zero. Two reset inputs are provided. One resets the actual hour meter to zero and the other resets the Overflow Alarm.

USER INTERFACE

The user interface consists of two push-buttons; labeled B1 and B2, the Setpoint/Variable Display, four LED indicators (I1-I4) and the Status LED indicator.

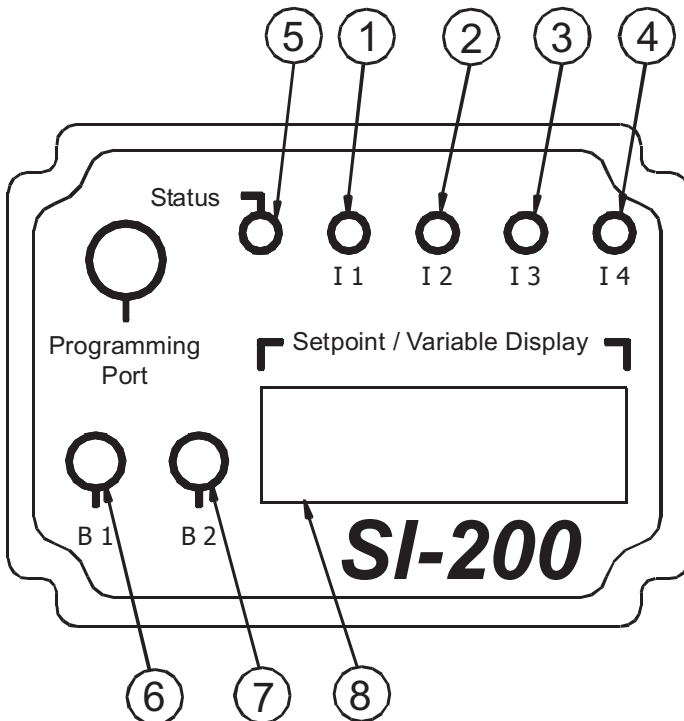

1. Indicator 1

On-Steady indicates that elapsed time is displayed on the Setpoint / Variable Display.

2. Indicator 2

On-Steady indicates that the Alarm/Setpoint 1 time is displayed on the Setpoint / Variable Display.

3. Indicator 3

On-Steady indicates that the Alarm/Setpoint 2 time is displayed on the Setpoint / Variable Display.

4. Indicator 4

Flashing indicates the hour meter has rolled over (> 9999) and has reset to zero.

5. Module Status Indicator

Flashing slowly indicates module problem
Flashing quickly indicates module is operating .

6. B1 Push-button

Each press will cycle one-step through the module menu.
1. Actual Elapsed Hours
2. Alarm/Setpoint 1
3. Alarm/Setpoint 2

7. B2 Push-button

For each Setpoint displayed, pressing the B1 will increment the displayed setpoint by one (1). Holding the B2 button will cause the setpoint to increment by 10's then 100's then 1000's.

8. Setpoint / Variable Display

View the current elapsed time, configure the setpoints.

Figure 2.3 - User Interface

INPUT CONNECTIONS

Two inputs are pre-programmed and must be wired to take advantage of functionality. Input 1 is used to reset the hour meter elapsed time. If this input is energized, the hour meter will reset immediately. Input 2 is used to reset the Overflow/Rollover Alarm. Figure 2.4 provides a sample connection. As shown in Figure 2.4, switches are used to illustrate what is required; although, any device that operates the same may be used.

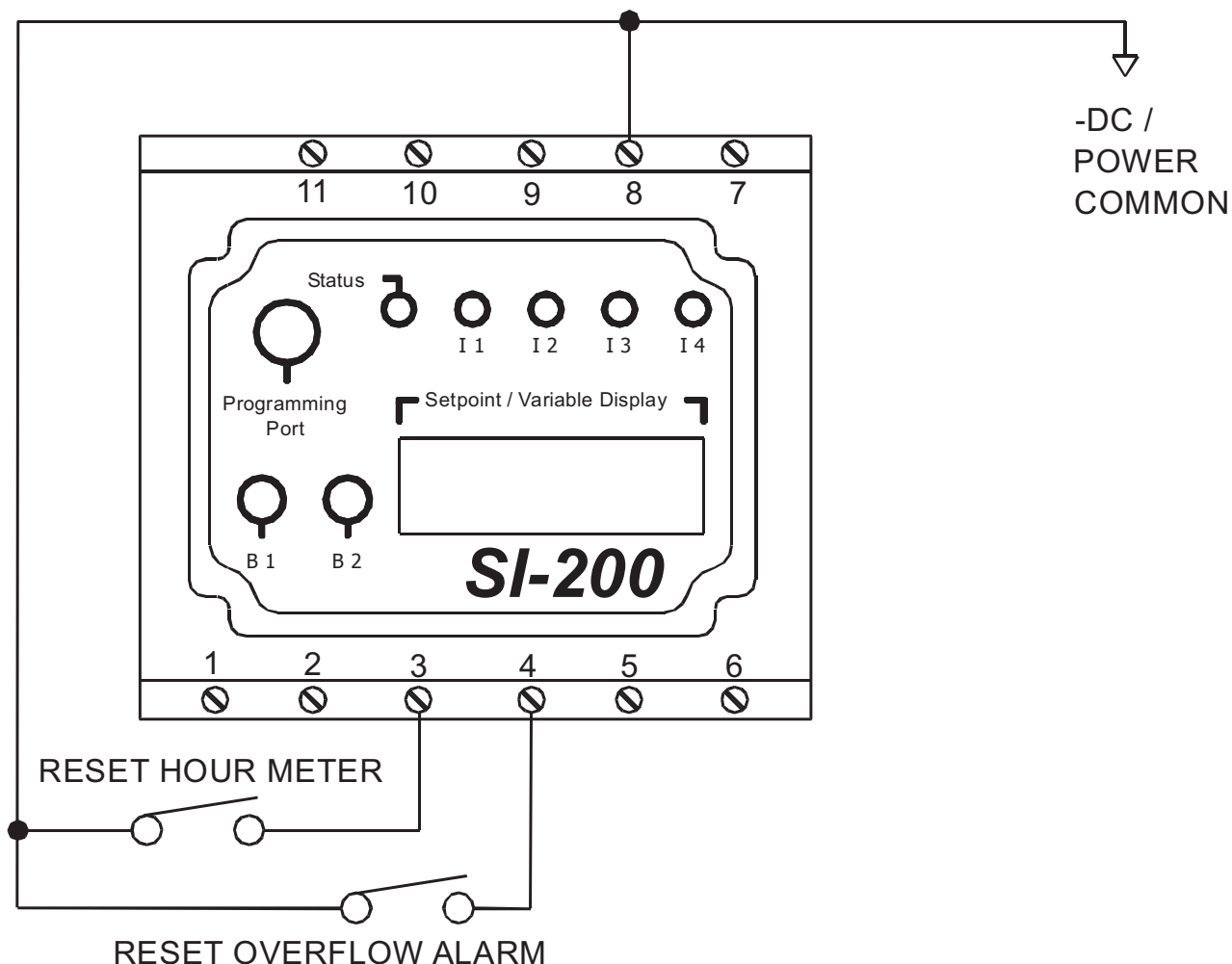



Figure 2.4 - Enable Input Connections

OUTPUT CONNECTIONS

When outputs are energized, the output pin will be sourced with +V (equal to the module input power voltage). Each output can drive a load up to 300mA maximum (resistive). Depending upon the device connected to an output, a minimum load resistor may be required. If the output is energized at all times, connect a 470Ω to 1KΩ load from the output to common. Figure 2.5 is a typical output wiring diagram.

 The factory installed software for this module will only allow two outputs to be energized at a time. Max total current for simultaneous outputs is 1ADC. Simultaneous output loads greater than 1A may result in damage to the module. Care must be taken to ensure the loads connected to the outputs if all channels are used does not exceed 1A.

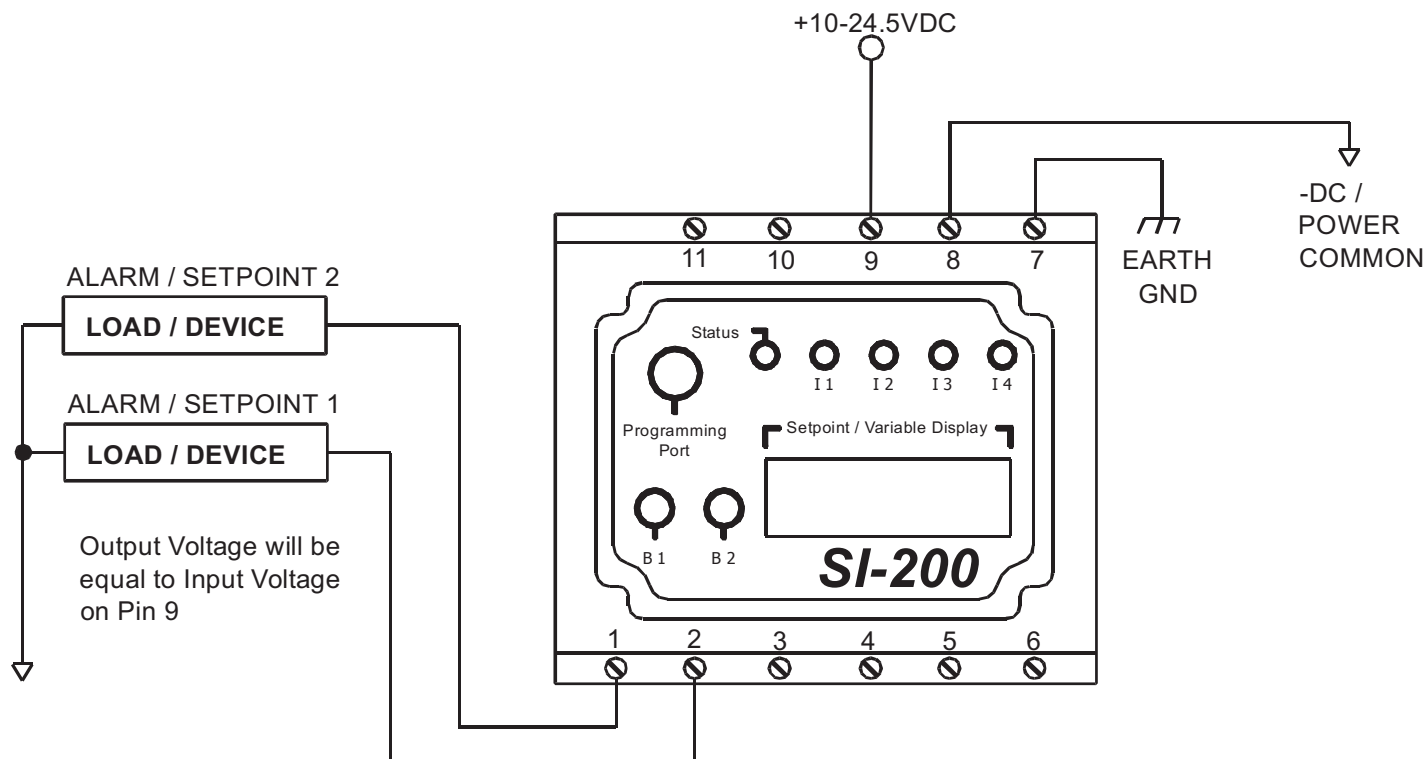

Figure 2.5 - Typical Output Connections

CHANGING SETPOINTS

Indicators I1-I3 represent in order: Current Elapsed Time (in hours), Alarm/Setpoint 1(in hours), Alarm/Setpoint 2 (in hours). Pressing the B1 button repeatedly will cycle through and display these items.

CHANGING THE SETPOINT

1. Using the B1 button, cycle through the menu until the alarm/setpoint is displayed (indicated by the I1-I3 indicators).
2. Press the B2 button repeatedly to increment the setpoint time in 1 hour increments. Pressing and holding the B2 button will cause the increment to increase to 10's, 100's then 1000's. The count will increase to 9999 counts then reset and begin from zero.

To exit from the setpoint, press the B1 button to the next menu item.

EXPANDABILITY / CUSTOMIZATION

As the module is based on the Solves-It!, Model SI-200, the program can be customized and its functionality expanded. Accessories are required. The program that was factory installed can be downloaded from <http://www.divelbiss.com>. The program can be edited to add additional functionality and logic. To gain functionality of some inputs and/or outputs, it may be necessary to re-assign the I/O that was factory configured. For more information about changing the functionality, download the Solves-It! User Manual and the EZ LADDER User Manual.

The following accessories are required to re-program the module and are included in the SI-APPMOD-PGMKIT:

- | | |
|--------------|------------------------------|
| 1. SI-PGM | Solves-It! Programming Cable |
| 2. EZLDCD-02 | EZ LADDER Lite on CD. |

PROGRAMMED FROM FACTORY SPECIFICATIONS

Processor:	Solves-It! Model 200, Based on PLC on a Chip™
Memory:	64K Flash
Outputs:	2 Sourcing SSR Outputs, rated 10-24VDC @ 300mADC Max. each. Max total output load = 1ADC @ 24VDC power input. Output Voltage = Input Power Functionality: Alarm/Setpoints 1 & 2
Power Requirements:	10-24.5VDC @ 150mADC Max
Indicators:	11-14 LED Indicator, 1 Status LED Indicator
Digital Inputs:	2 Sourcing Inputs Hourmeter Reset / Hourmeter Overflow Alarm Reset
Display:	4 Digit, 7 Segment Programmable LED Display
Push Buttons:	2 Programmable Push Buttons
Operating Temp:	0-60° C
Dimensions:	3.62" Wide x 5.21" Length x 1.21" Tall.
Mounting:	Plugs into Industry standard 11-pin Octal Relay Socket
Type:	Plastic Housing

Limited Warranty

Divelbiss Corporation warrants equipment will be free from defects in material and workmanship for a period of one (1) year from the date of the Divelbiss invoice that the equipment was furnished. Divelbiss Corporation will not be liable for any design furnished by Buyer and incorporated into the equipment.

In no event shall Divelbiss Corporation be liable for anticipated profits, consequential damages or loss of use of equipment or of any installation into which the equipment covered by this order may be put.

Divelbiss Corporation shall not be liable or responsible for any loss, injury, or damage resulting directly or indirectly from the use of software and/or programming in any way associated with the equipment of this order.

Obligations are to be limited to the repair or replacement at the Divelbiss Corporation plant, Fredericktown, Ohio, upon return of the part or component in question, prepaid by Buyer. The return freight charges to be paid by Divelbiss. The part or component is only to be returned to Divelbiss with a Returned Material Authorization number issued by the Divelbiss Service Department. Any warranty service (consisting of time, travel, and expenses related to such services) performed other than at Divelbiss Corporation plant, shall be at Buyer's expense.

Warranty of repaired or replacement products will be limited to ninety (90) days or the remainder of the original warranty whichever is greater.

Warranty is available only if Divelbiss Corporation is promptly notified in writing upon discovery of any alleged defect and examination of the subject product discloses, to Divelbiss satisfaction, that any defect has not been caused by misuse; neglect; improper installation; improper operation; improper maintenance, repair, or alteration; accidents; or unusual deterioration or degradation of the equipment or parts thereof due to physical environment or due to electrical or electromagnetic noise environment.

This warranty is in lieu of all other warranties, expressed, implied, or statutory, including warranties of merchantability or fitness for a specific purpose.