

**Programs
in Ladder
Logic**



PLC on a Chip Patent 7,299,099

SOLVES-IT! ANALOG User's Manual

REV .2



Smart Parts for Managing Automation

9778 Mt. Gilead Rd.
Fredericktown, OH 43019
Toll Free: 1-800-245-2327
Web: <http://www.divebiss.com>
Email: sales@divebiss.com

IMPORTANT INFORMATION

REGARDING SOLVES-IT CONTROLLER SHIPMENTS

To provide greater flexibility and reliability, *Solves-It!* Analog shipments are factory programmed without a KERNEL. You must install the kernel prior to being able to download EZ LADDER programs.

To install a target kernel:

1. Connect the serial cable from the PC to the SI-110 / SI-210 (Programming Port).
2. Open the EZ LADDER Toolkit.
3. To load the kernel, you must configure the target and have at the minimum a one-rung program. For your convenience a program is pre-loaded on your computer (for EZ LADDER versions 1.0.4.4 and later). The file is named **GetStarted_SI-110_SI-210.dld** and can be found in the Kernel Install Start Programs sub-directory where you installed EZ LADDER.

OR

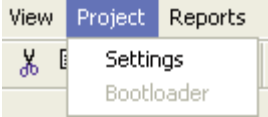
Otherwise, create your own using the **Projects....Settings** Menu,  select the "Solves-IT" target and click the PROPERTIES button. Using the drop down menu, select the Solves-it model; either SI-110 or SI-210 and click OK. You may also load a pre-saved ladder diagram that uses the same target. Verify the COM port is set correctly and click OK to exit the *Project Settings*. See the EZ LADDER User's Manual for details on configuring targets.

4. Click the  (Monitor) button to change from the 'Edit' to 'Monitor' Mode.

5. Click the  (Connect) button to connect to the target. A dialog will appear automatically when no kernel is loaded.

6. Click the **BROWSE** button and select the target's kernel (**by partnumber**) located by default at *C:\Program Files\EZ Ladder\Kernel*

The following is the kernel name and description:

<u>File Name</u>	<u>Description</u>	<u>To be Used on (Partnumber)</u>
Solves_It_SI_110.dat	Kernel for Solves-It Analog	SI-110, SI-210

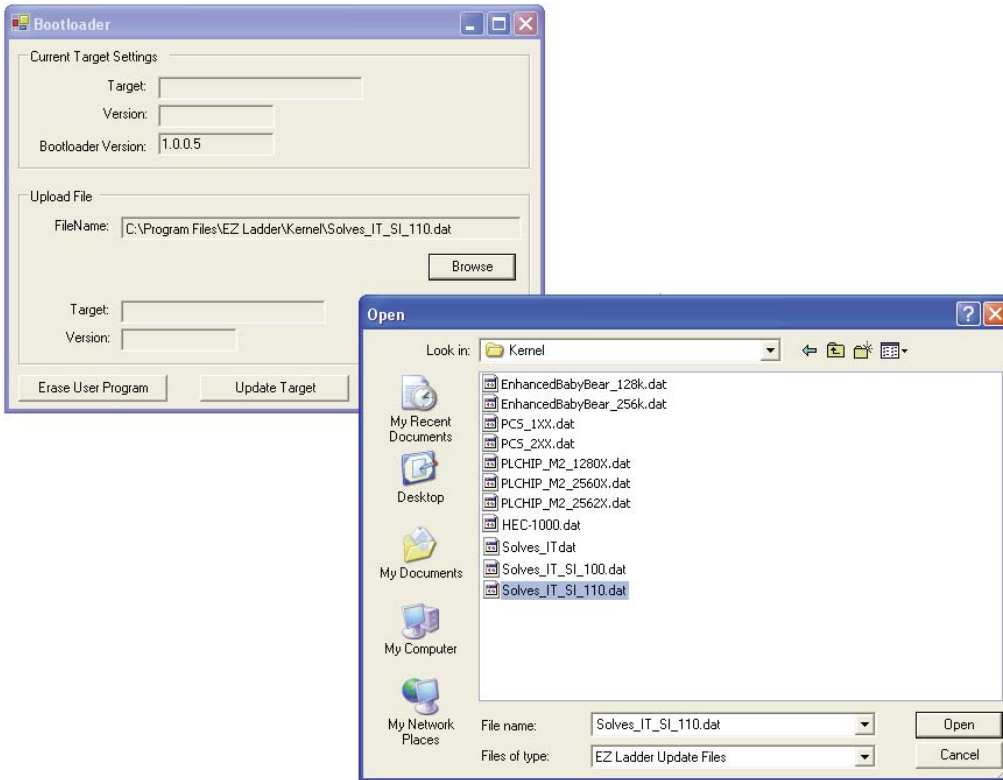

7. Click the **OPEN** button to finish the kernel selection. Make sure the correct kernel is chosen.
8. Click the **UPDATE TARGET** button to install the kernel.

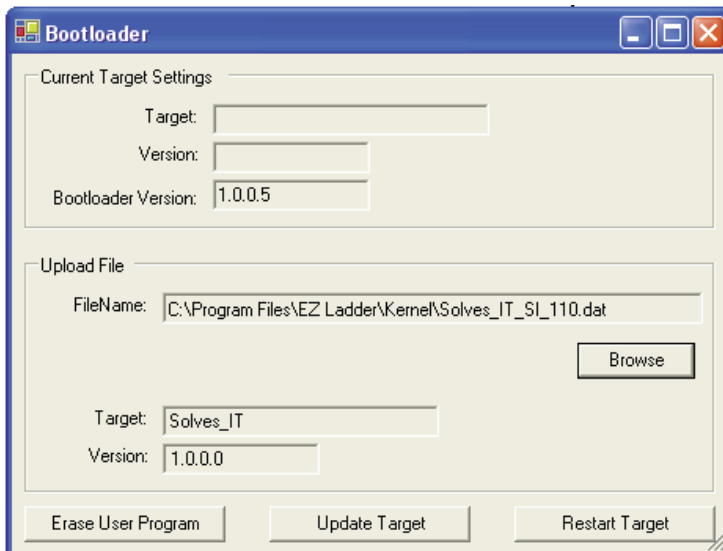

9. A dialog box will appear to show the status of the kernel installation. This could take a couple of minutes to install.
10. When the dialog windows close, the installation is complete. The Solves-It may be connected to normally and programs may be downloaded.

TABLE OF CONTENTS

Table of Contents	Page 1
Package Contents	Page 1
Getting Started	Page 2
How to Use this Manual	Page 2
Configuring the Solves-It! Analog Target in EZ LADDER	Page 3
Solves-It! Analog Common Features	Page 4
Getting to Know the Solves-It! Analog	Page 4
Solves-It! Analog Mounting	Page 5
Solves-It! Analog Input Power	Page 5
Status LED	Page 6
Programming Port	Page 6
Dual Function I/O	Page 7
Counter Inputs	Page 8
Dedicated Digital Outputs	Page 9
LED Indicators	Page 10
Retentive Memory	Page 10
Analog Inputs	Page 11
EEPROM Memory	Page 12
Specifications	Page 12
SI-210 Exclusive Features	Page 13
Real Time Clock	Page 14
Programmable Push Buttons	Page 14
Programmable Display	Page 14

WARNING!

The SI-110 or SI-210, as with programmable controllers, must not be used alone in applications which would be hazardous to personnel in the event of failure of this device. Precautions must be taken by the user to provide mechanical and/or electrical safeguards external to this device. This device is **NOT APPROVED** for domestic or human medical use.

PACKAGE CONTENTS

Whats Included

Qty	Description	Part Number	Location
1	Controller	SI-110 or SI-210	In Box
6	Commutating Diodes	111-101012	In Box

GETTING STARTED

This section explains how to read this manual and understand the symbols.

HOW TO USE THIS MANUAL

In this manual, the following conventions are used to distinguish elements of text:

BOLD	Denotes labeling, commands, and literal portions of syntax that must appear exactly as shown.
<i>italic</i>	Used for variables and placeholders that represent the type of text to be entered by the user.
SMALL CAPS	Used to show key sequences or actual buttons, such as OK, where the user clicks the OK button.

In addition, the following symbols appear periodically in the left margin to call the readers attention to specific details in the text:



Warns the reader of a potential danger or hazard that is associated with certain actions.



Appears when the text contains a tip that is especially helpful.



Indicates that the text contains information to which the reader should pay particularly close attention.

All Specifications Subject to Change without Notice

CONFIGURING THE SOLVES-IT! TARGET IN EZ LADDER

Before you can program and use the Solves-It! Analog Controller, it must be configured as a target within EZ LADDER. For help with installing or using EZ LADDER, please refer to the EZ LADDER User's Manual.

In EZ LADDER, select **PROJECT....SETTINGS**. This will open the *Project Settings Window*. Select "Solves-It" for the target. Click on **PROPERTIES**. The Solves-It dialog box will open. Using the drop down menu, select the correct Solves-It! Analog model and click **OK**. Click **OK** again to close the *Project Settings Window*. Figure 1.1 show the *Project Settings Window and Solves-It Properties* dialog box.

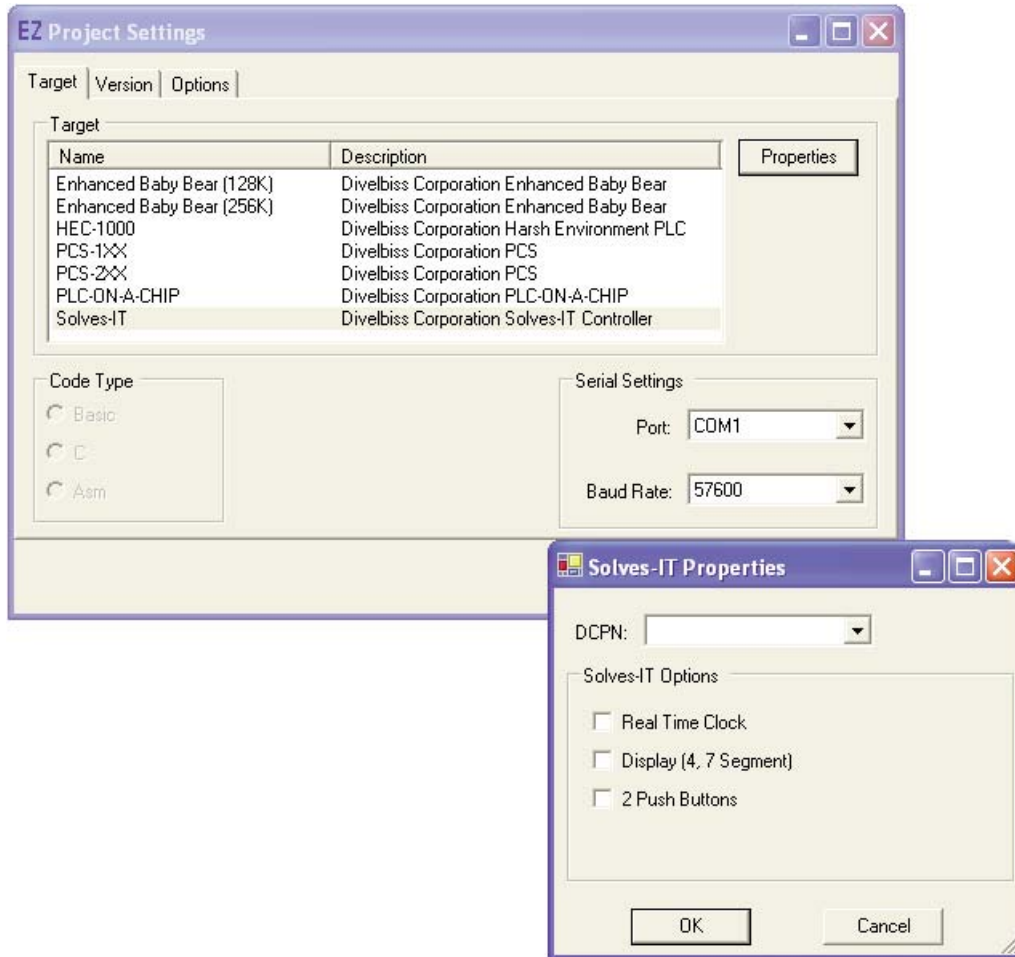

Figure 1.1

Once you have configured the Solves-It! Analog target, EZ LADDER automatically creates variables for the Inputs, Outputs, Programmable LEDs and Programmable Push Buttons (SI-210 only). For each variable, the appropriate I/O address is automatically programmed for quick reference to use in the ladder program. **Please note: The Solves-It! Analog incorporates dual function I/O.** This means that the first 4 digital I/O may be used as either inputs or outputs, but not both. Only use the variable type (input or output) that is needed in your program.

The following variables are created automatically:

I/O Point	Input Address (Variable Name)	Output Address (Variable Name)	Description	Variable Name	I/O Address	Description
GPI00	GPI0 (GPI0)	GPO0 (GPO0)	Digital I/O 0	LED1	LED1	Programmable LED # 1 (I1)
GPO11	GPI1(GPI1)	GPO1 (GPO1)	Digital I/O 1	AI0	AI0	Analog Input 1 - External
GPOI2	GPI2 (GPI2)	GPO2 (GPO2)	Digital I/O 2	AI1	AI1	Analog Input 2 - Potentiometer 1
GPI03	GPI3 (GPI3)	GPO3 (GPO3)	Digital I/O 3 / CNTR	AI2	AI2	Analog Input 3 - Potentiometer 2
GPO4	---	GPO4 (GPO4)	Digital Output 4			
GPO5	---	GPO5 (GPO5)	Digital Output 5			

SOLVES-IT! ANALOG COMMON FEATURES

This section describes the hardware features and options including using EZ LADDER to operate the hardware that are common for all Solves-It! Analog models.

GETTING TO KNOW THE SOLVES-IT! ANALOG

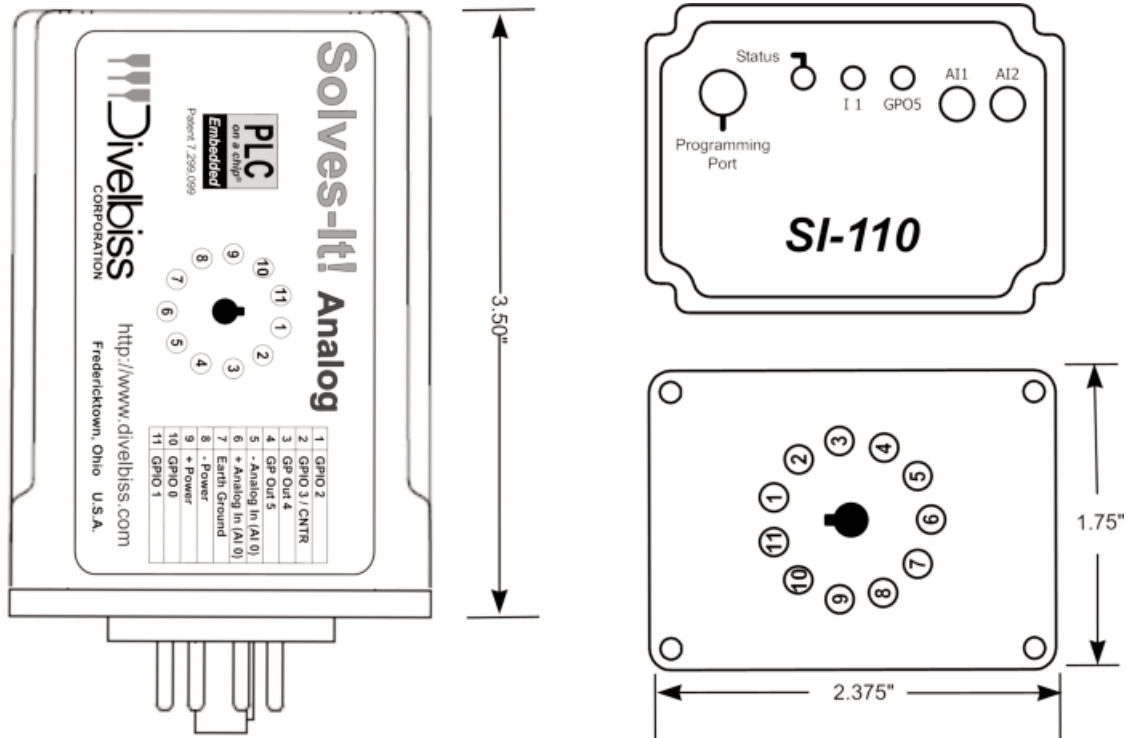

The Solves-It! Analog is connected to external devices via its mounting socket, Divelbiss part number 115-105328 (not supplied), once it has been mounted. The Solves-It! Analog is programmed via its programming port using the programming cable SI-PGM.

Connector Pin out

Bottom View (Solves-It! Connector)

- Pin 1 GPIO2
- Pin 2 GPIO3 / High Speed Counter (CNTR)
- Pin 3 GPO4
- Pin 4 GPO5
- Pin 5 AI0-
- Pin 6 AI0+
- Pin 7 Earth Gnd
- Pin 8 - Power (Common)
- Pin 9 +VDC Input Power
- Pin 10 GPIO0
- Pin 11 GPIO1

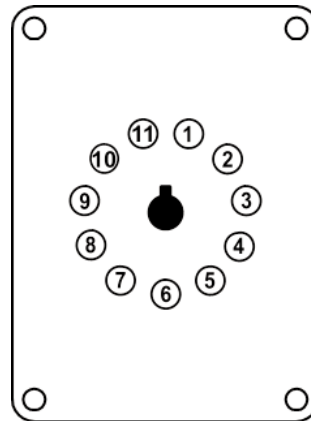

Figure 2.1 - Solves-It! Analog Connections

SOLVES-IT! ANALOG MOUNTING

The Solves-It! Analog Controller mounts to industry standard 11-pin Octal relay socket. To mount the Solves-It!, align with the socket and firmly push into position.

SOLVES-IT! ANALOG INPUT POWER

The Solves-It! may be powered using 8-32VDC. The input power must be of sufficient supply to drive the Solves-It! controller and all the digital I/O (based on the load currents for each) Maximum current for the Solves-It! Analog is 150mADC and maximum load for each outputs is 500mADC. See Figure 2.2.

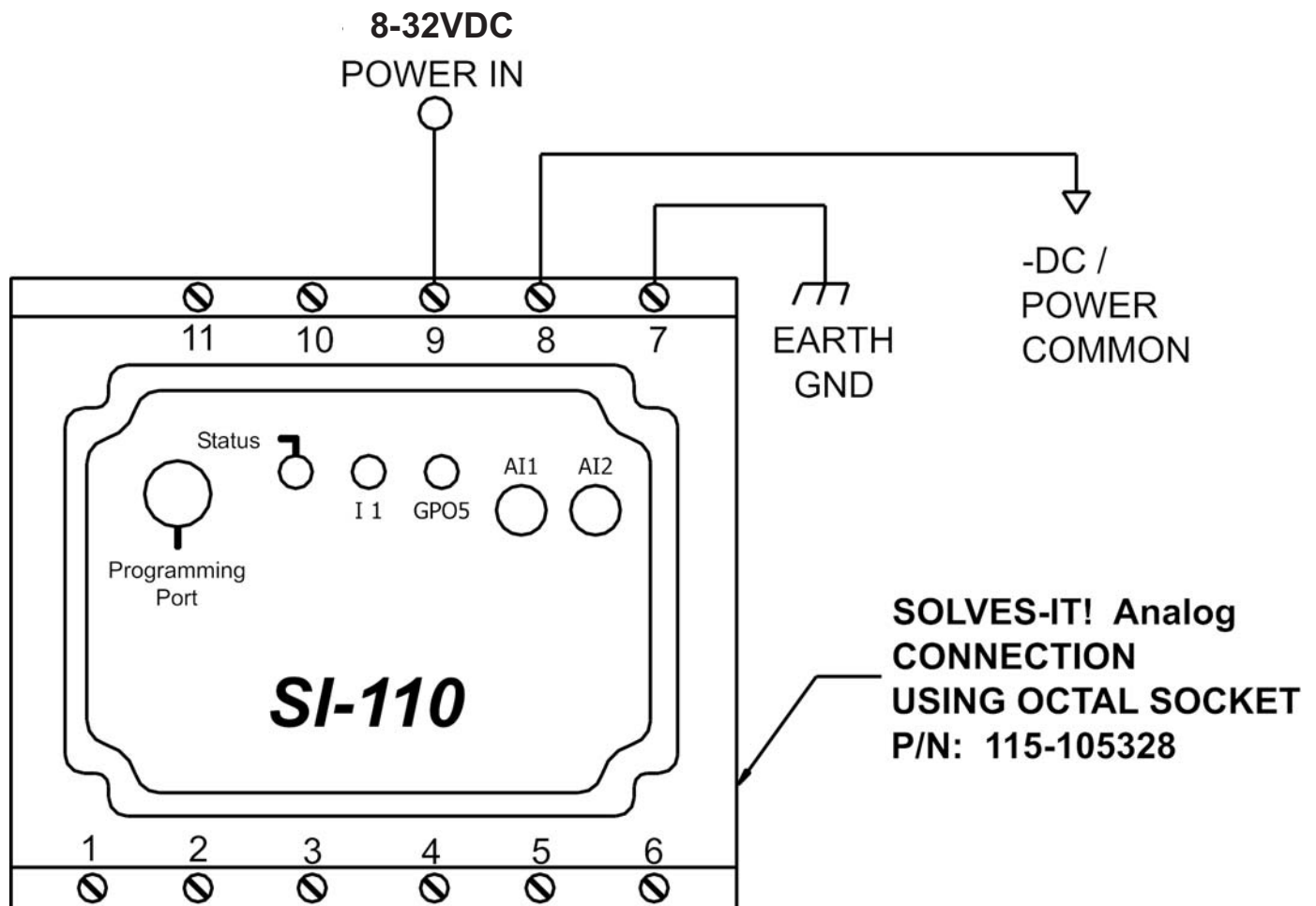

Figure 2.2 - Solves-It! Analog Input Power

STATUS LED



The operating status of the Solves-It! Analog can be determined the by Status LED. When the Status LED is flashing at a slow rate, approximately once per second, then there is no program executing. When the Status LED is flashing at a fast rate, approximately 10 times per second, a program has been loaded and it is executing.

Should the Status LED not flash at all, first check the input power. If the input power is correct and there is still no Status LED, contact Divalbiss Technical Services.

PROGRAMMING PORT

The Solves-It! Analog is programmed using its Programming Port. This RS232 serial port is only to be used for programming using Divalbiss' EZ LADDER. The Programming Port defaults to 57600,N,8,1. This is not a general purpose port. See Figure 2.3.

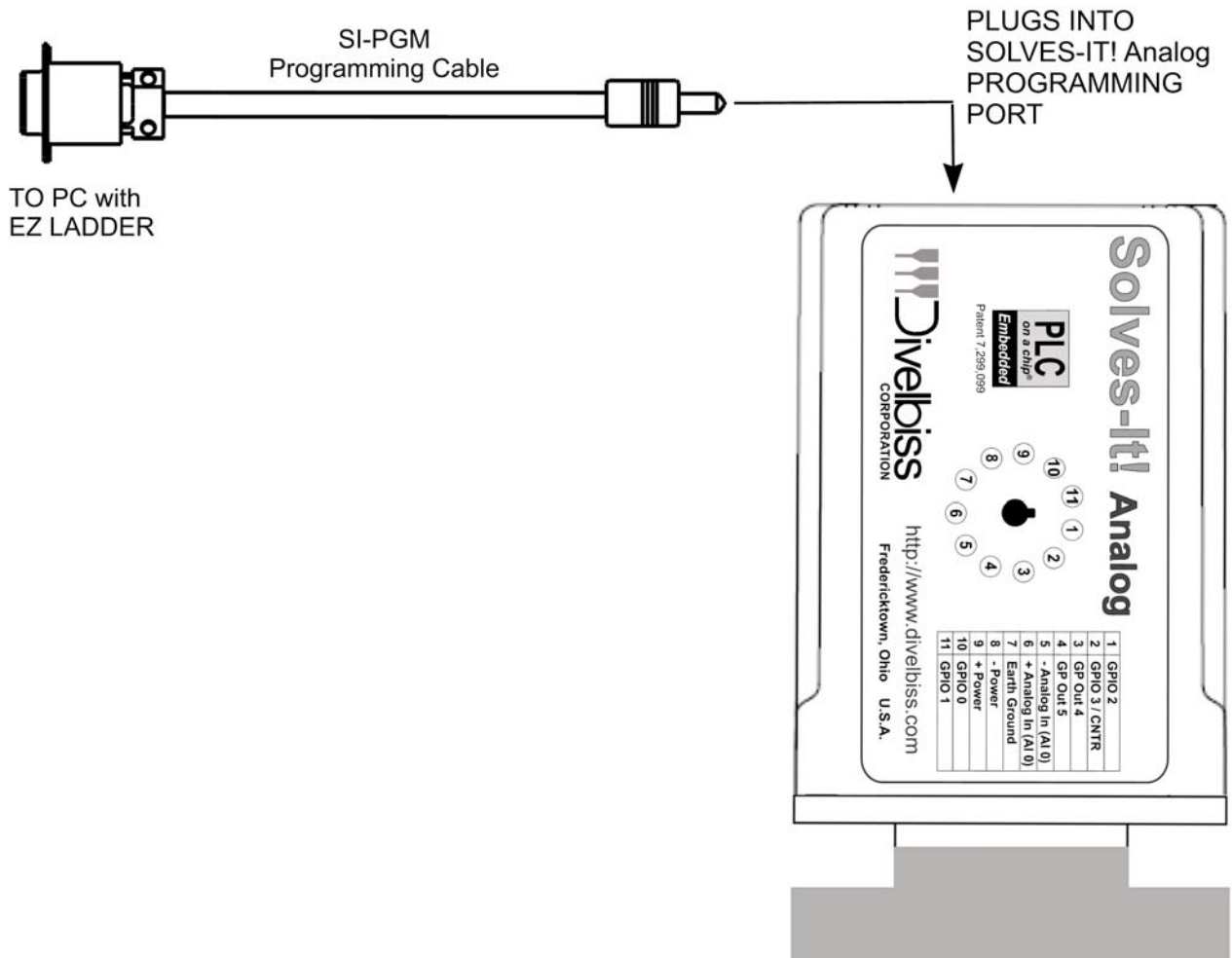

Figure 2.3 - Programming Port

DUAL FUNCTION I/O

The Solves-It! includes 4 on-board dual function I/O points. These points (GPIO0 - GPIO3) can be individually used as either a digital input or a digital output. All digital inputs are optically isolated to promote noise immunity. When used as an output, the input may be used to 'monitor' the output status.

GPIO3 may be used as a general purpose input, output or high speed counter; while GPIO0, GPIO1 & GPIO2 can only be used as general purpose inputs or outputs. For information on using GPIO3 as a high speed counter input, refer the COUNTER INPUTS Section, page 11 of this manual.

To access the digital inputs in the ladder diagram, use the DIRECT CONTACT and INVERTED CONTACT objects and Input addresses GPIO0 - GPI3. See Figure 2.4A connections to use dual function I/O as inputs. Inputs are true when connected to +V.

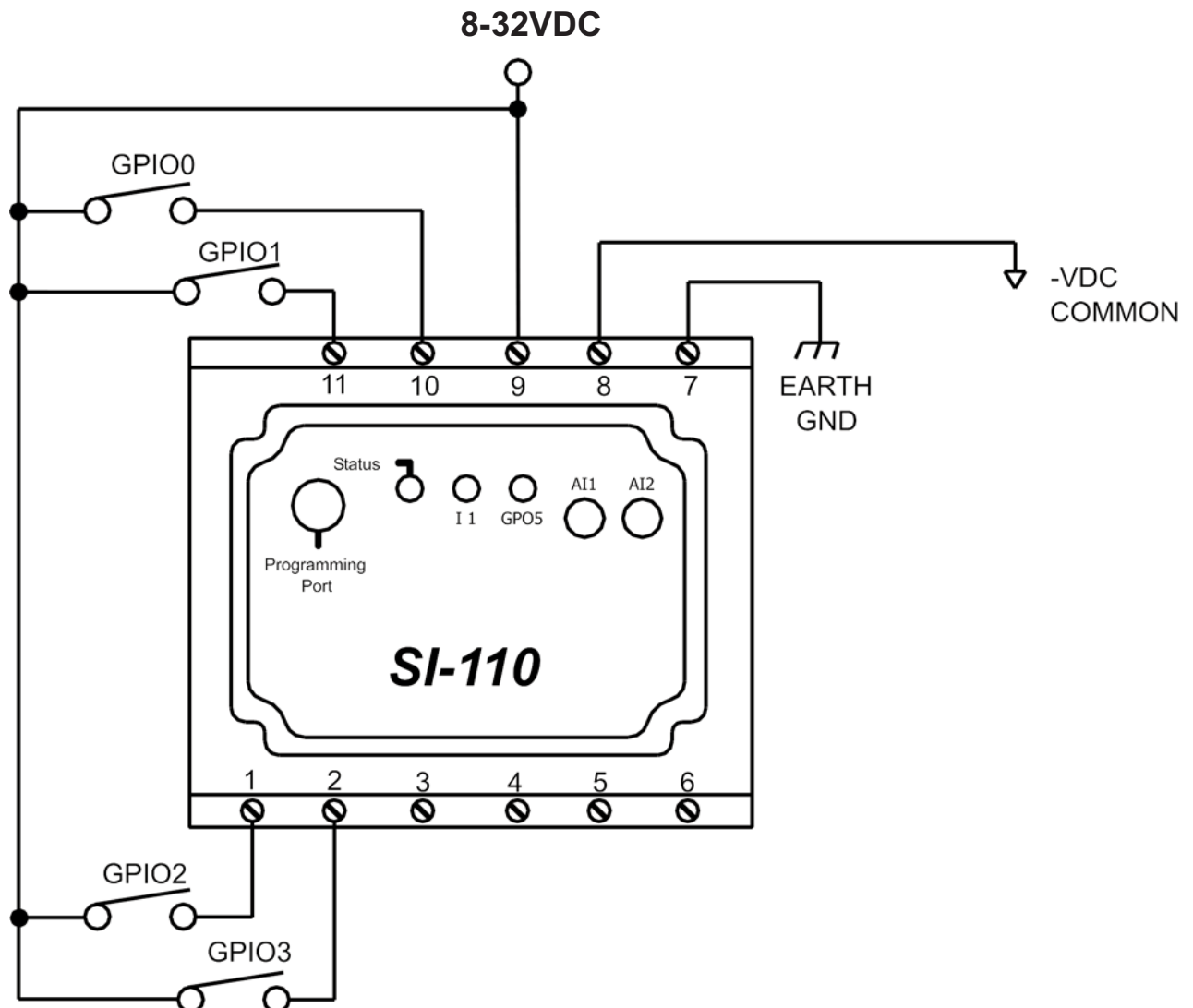

Figure 2.4A - Typical Digital Input Connections

To access the digital outputs in the ladder diagram, use the DIRECT COIL and INVERTED COIL objects and Output addresses GPO0 - GPO3. See Figure 2.4B connections to use dual function I/O as outputs. When outputs are true, the output pin will be sourced with +V. Each output can drive a load up to 500mA maximum (resistive). Depending upon the device connected to an output, a minimum load resistor may be required. If the output is "ON" at all times, connect a 470Ω to 1KΩ load from the output to common.

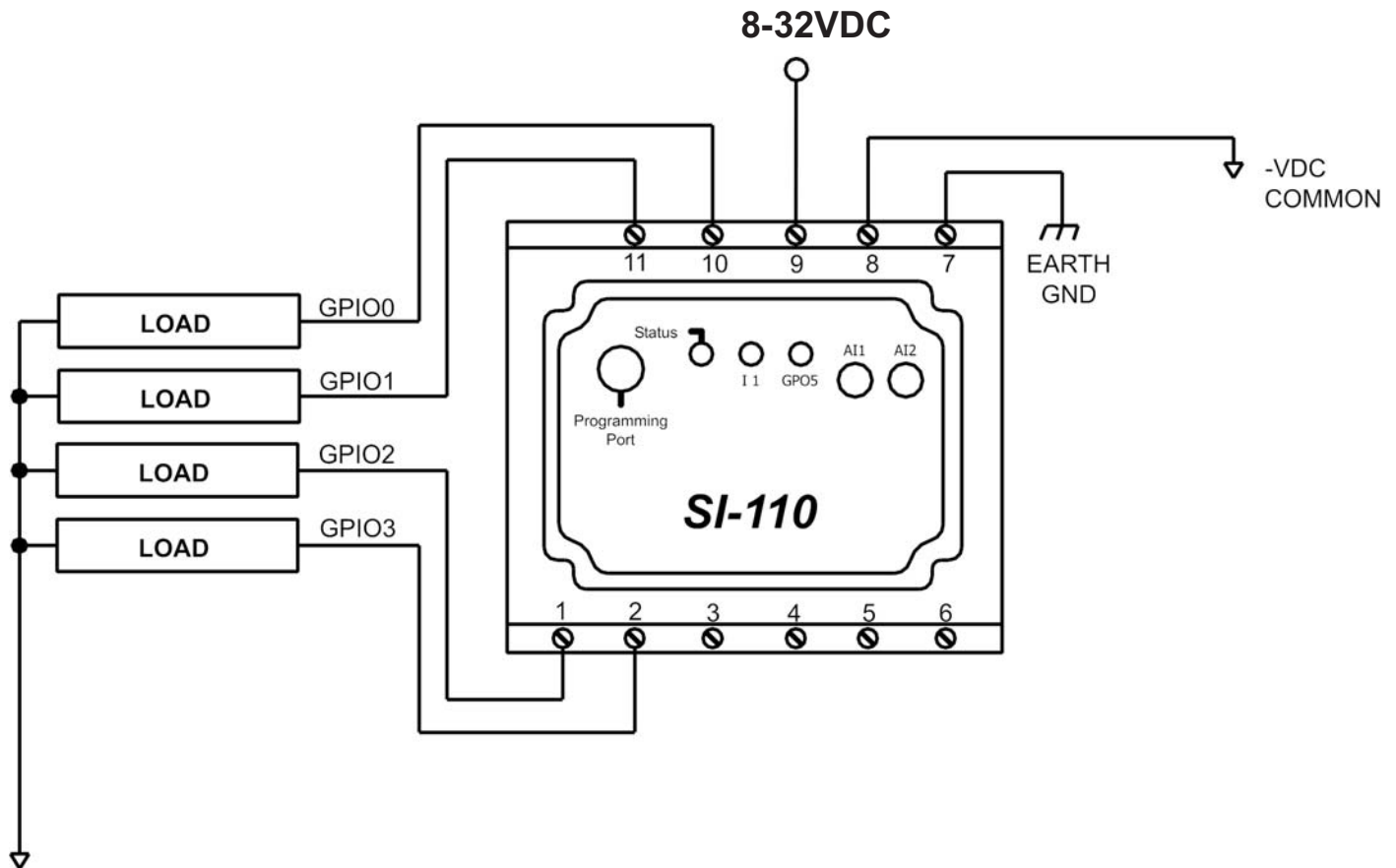

Figure 2.4B - Typical Digital Output Connections

COUNTER INPUTS

One of the dual function I/O points (GPIO3) may be utilized as a high speed counter (up count). The GPIO3 input will operate as a counter up to the maximum input rate of 25KHz. The counter input is optically isolated to promote noise immunity. The High speed counter input uses the EZ LADDER function: CNTRTMR. The counter input pulse device must provide a +V input signal for proper operation.

Typical High Speed Counter connections are shown in Figure 2.6.

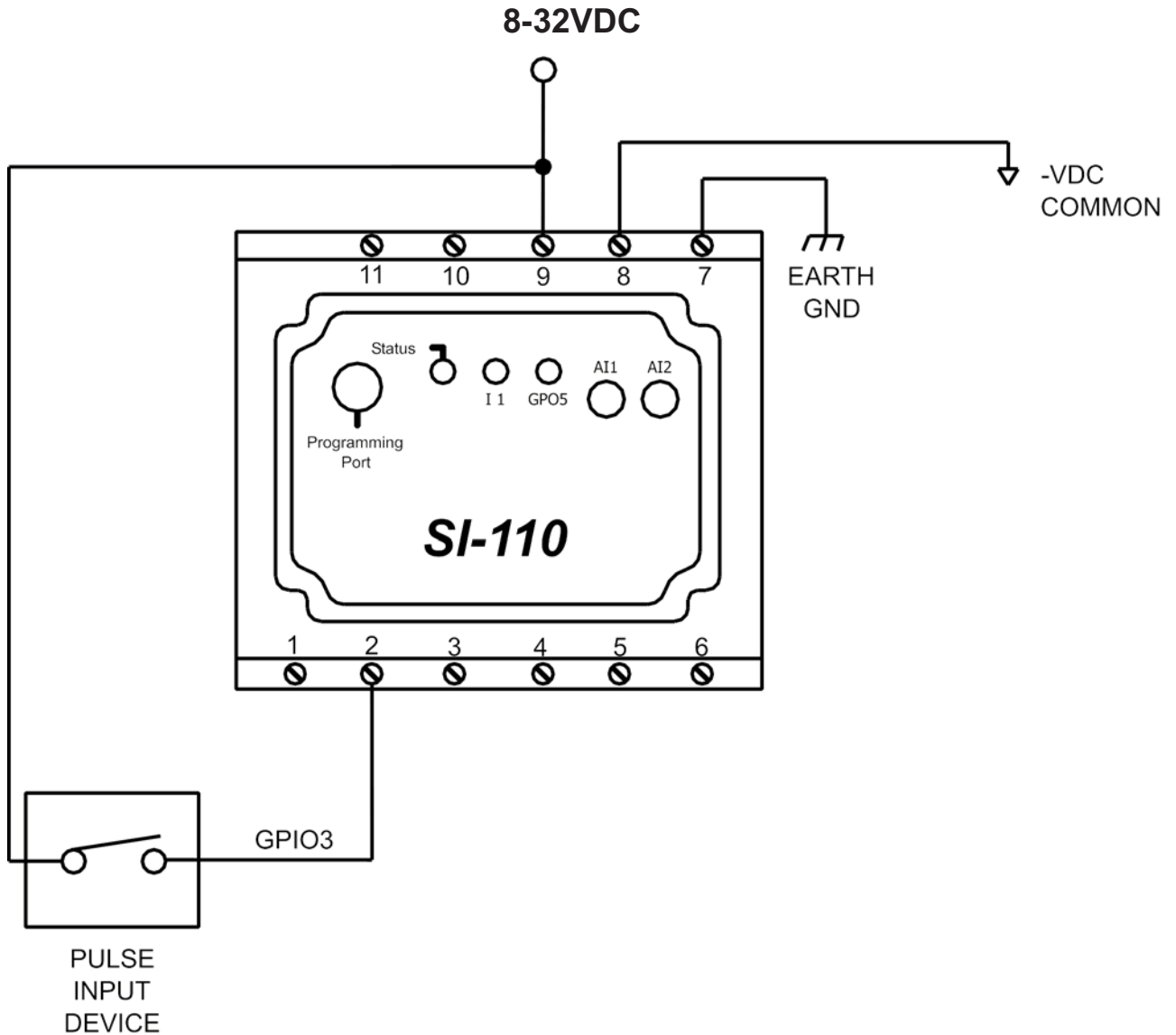

Figure 2.5 - Typical Counter Input Connections

DEDICATED DIGITAL OUTPUTS

The Solves-It Analog includes 2 on-board dedicated digital outputs. They are identified as GPO4 - GPO5. The output voltage will be equal to the Solves-It's input voltage. Each output can drive a load up to 500mA maximum (resistive). Depending upon the device connected to an output, a minimum load resistor may be required. If the output is "ON" at all times, connect a 470Ω to 1KΩ load from the output to common. GPO5 status is also indicated by the GPO5 LED.

To access the digital outputs in the ladder diagram, use the DIRECT COIL and INVERTED COIL objects.

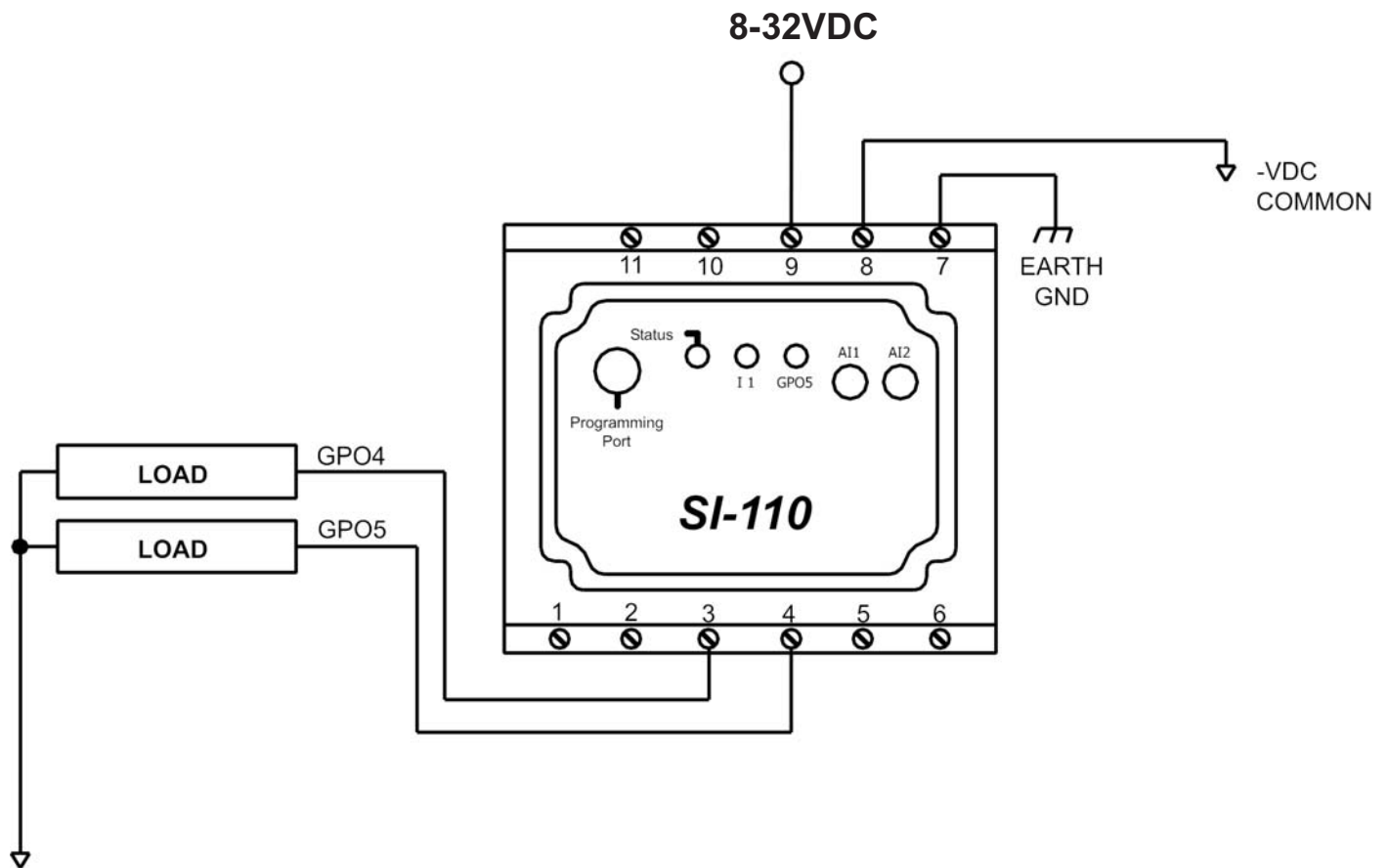

Figure 2.6 - Typical Digital Output Connections

LED INDICATORS

The Solves-It includes 1 on-board programmable LED indicators (labeled on the case as I1). This indicator may be used to identify or indicate any condition in the ladder logic program. This LED indicator I/O address is LED1. See Figure 2.7.

To access the LED Indicators in the ladder diagram, use the DIRECT COIL and INVERTED COIL objects. This indicator automatically has a variable labeled LED1.

GPO5 is an indicator LED for the GPO5 digital output and is directly connected to the output. The LED is ON when the output is True or ON.

RETENTIVE MEMORY

The Solves-It Analog models with Real Time Clock (SI-210) support the use of Retentive Memory. The variables must be 'declared' retentive in the EZ LADDER program to operate properly.

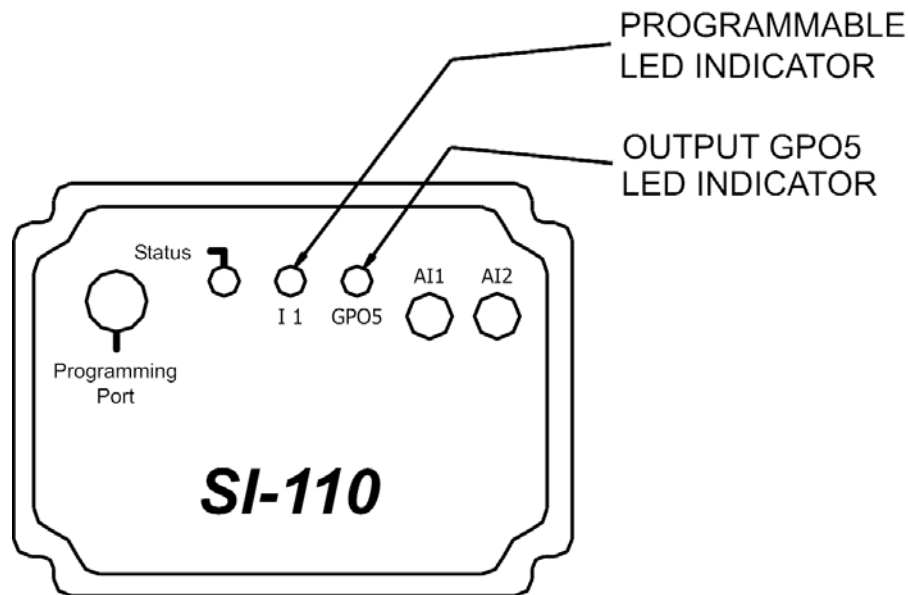

Figure 2.7 - LED Indicators

ANALOG INPUTS

The Solves-It! Analog has three analog inputs. The first, AIO is an external analog input that will accept a differential input signal of 0-10VDC or 0-20mADC with the addition of an external resistor. It is accessed in the EZ LADDER program by the variable AI0.

The other two analog inputs are internal to the Solves-It! Analog. They are connected to potentiometers that can be adjusted through the top of the Solves-It!'s plastic housing. These analog inputs (AI1, AI2) simply provide potentiometer adjustments for the use in any application for timer adjustments, etc.. To access them in the EZ LADDER program use variables AI1 and AI2.

Each of the analog inputs will be represented using the variable as an integer number between 0 and 1023 (0 = 0VDC or Potentiometer set to minimum; 1023 = 10VDC or Potentiometer set to maximum).

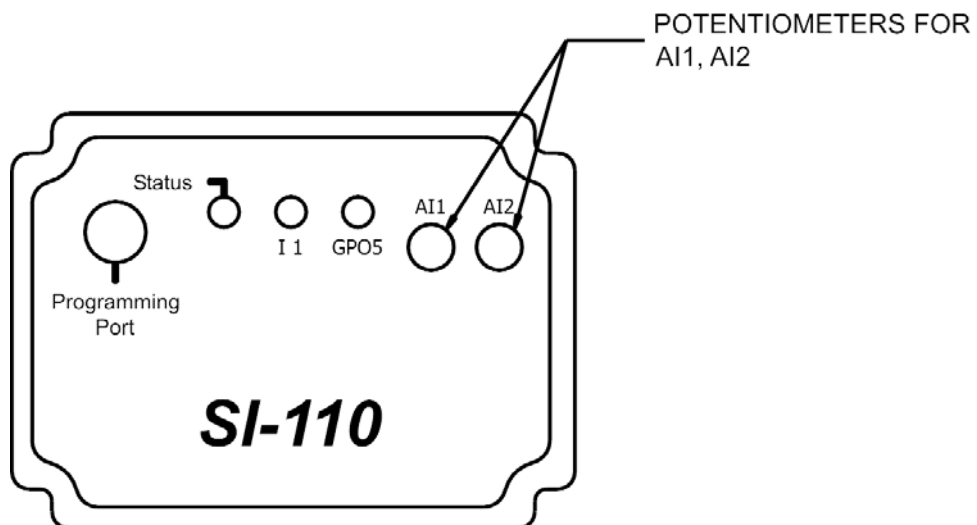

Figure 2.8 - Analog Input Potentiometers

EEPROM MEMORY

As one of the standard features of PLC on a Chip™ and EZ LADDER Toolkit, the SI-110/SI-210 supports the use EEPROM memory that may be used to store and recall boolean, integer, real and timer values in non-volatile memory in the ladder diagram. This can be used to store field adjustable set points and more.

The SI-110/SI-210 supports 128 bytes of EEPROM memory. This memory is accessed in the ladder diagram using the EEPROM_READ and EEPROM_WRITE Function blocks. The same variable type that writes to the EEPROM location should be used to read the EEPROM location. A memory map is recommended for organizing variables stored in EEPROM.

Each EEPROM address is absolute and is one byte in size. Boolean variables fill two bytes while all other variable types fill four bytes of EEPROM. When writing a boolean to address 0, the actual variable will use addresses 0 and 1 (two bytes). Should you write an integer variable into address 0, then it would use addresses 0-3. A memory map should be created and used to assign variable types and addresses prior to coding to ensure that variable size and types are accounted for.

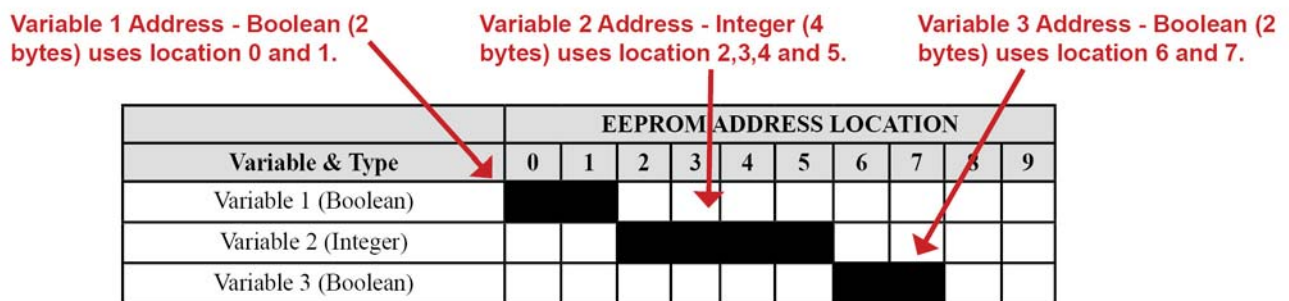

Figure 2.8 - EEPROM Memory

EEPROM storage area has a limited number of write cycles; therefore it shouldn't be used to store data which changes often and must be re-written often. Writing often to the same location can cause the location to fail.

SPECIFICATIONS

Processor:	PLC on a Chip™
Memory:	64K Flash, 128 Bytes EEPROM
Serial Ports:	1 Programming Port (Max baud: 57.6K);
Digital I/O:	4 Sinking Inputs, rated 8-32VDC.
	6 Sourcing SSR Outputs, rated 8-32VDC @ 500mADC Max. each. Output Voltage = Input Power
Real Time Clock*:	Time of Day, Day, Month, Year & Day of Week
Counters:	1 Channel, Count Up. GPIO3 = 25KHz Max.
Power Requirements:	8-32VDC @ 150mADC Max (Excludes I/O)
Indicators:	1 Programmable LED Indicator, 1 Status LED Indicator, 1 Output LED Indicator (GPO5)
Analog Inputs:	1 0-10VDC External, 2 Internal Potentiometer
Display*:	4 Digit, 7 Segment Programmable LED Display
Push Buttons*:	2 Programmable Push Buttons
Operating Temp:	-40-65° C
Program Language:	Ladder Logic using Divelbiss EZ LADDER
Dimensions:	2.4" Wide x 1.75" Length x 4.2" Tall.
Mounting:	Plugs into Industry standard 11-pin Octal Relay Socket
Type:	Plastic Housing

* Indicates features only available on model SI-210.

SI-210 EXCLUSIVE FEATURES

This section describes the hardware features and options including using EZ LADDER to operate the hardware that is specific to the Solves-It! Model 210 (SI-210).

REAL TIME CLOCK

The SI-210 includes a Real Time Clock. The real time clock (after being set) provides the Month, Day, Day of the Week, Year, Hour, Minute and Second. The real time clock maintains time when power is lost via lithium battery. The Real Time Clock may be accessed using the EZ LADDER functions: GETDATE, GETTIME, SETTIME, SETDATE.

PROGRAMMABLE PUSH BUTTONS

The SI-210 includes two programmable push buttons (labeled on the case as PB1 and PB2). These push buttons are I/O addressed using PB1 and PB2 in EZ LADDER.

To access the push buttons in the ladder diagram, use the DIRECT CONTACT and INVERTED CONTACT objects. These push buttons are automatically have variables labeled PB1, PB2. See Figure 3.1.

PROGRAMMABLE DISPLAY

The SI-210 includes a programmable 4 digit, seven-segment display. This display may be used to display setpoints, actual timers and more. See Figure 3.1.

To access the display in EZ LADDER, use the SI_DISP and SI_CLRDISP

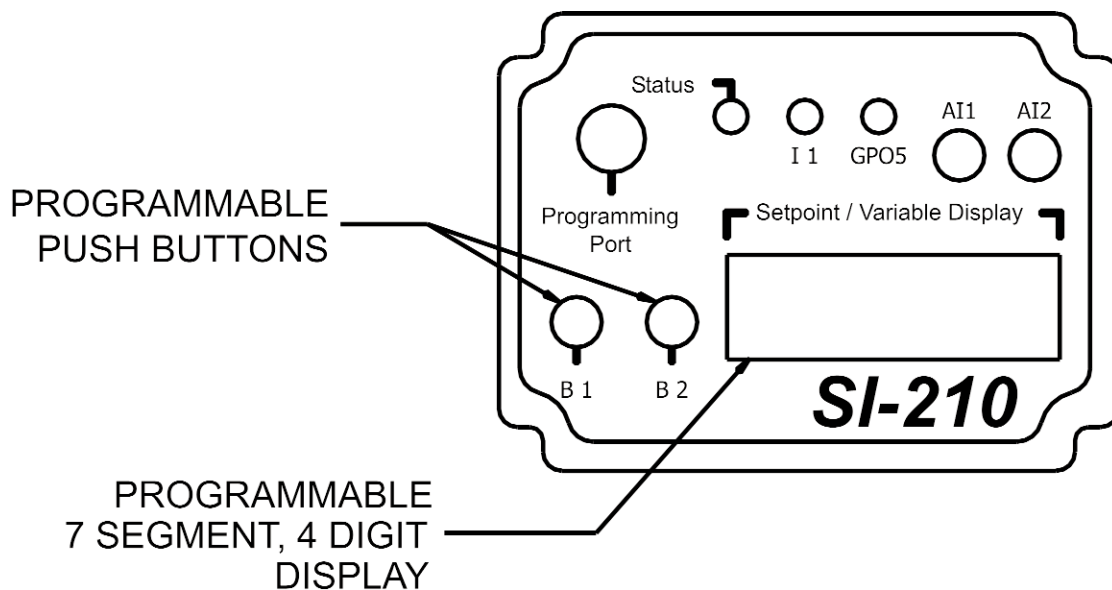

Figure 3.1 - Push Buttons and Display

Limited Warranty

Divelbiss Corporation warrants equipment will be free from defects in material and workmanship for a period of one (1) year from the date of the Divelbiss invoice that the equipment was furnished. Divelbiss Corporation will not be liable for any design furnished by Buyer and incorporated into the equipment.

In no event shall Divelbiss Corporation be liable for anticipated profits, consequential damages or loss of use of equipment or of any installation into which the equipment covered by this order may be put.

Divelbiss Corporation shall not be liable or responsible for any loss, injury, or damage resulting directly or indirectly from the use of software and/or programming in any way associated with the equipment of this order.

Obligations are to be limited to the repair or replacement at the Divelbiss Corporation plant, Fredericktown, Ohio, upon return of the part or component in question, prepaid by Buyer. The return freight charges to be paid by Divelbiss. The part or component is only to be returned to Divelbiss with a Returned Material Authorization number issued by the Divelbiss Service Department. Any warranty service (consisting of time, travel, and expenses related to such services) performed other than at Divelbiss Corporation plant, shall be at Buyer's expense.

Warranty of repaired or replacement products will be limited to ninety (90) days or the remainder of the original warranty whichever is greater.

Warranty is available only if Divelbiss Corporation is promptly notified in writing upon discovery of any alleged defect and examination of the subject product discloses, to Divelbiss satisfaction, that any defect has not been caused by misuse; neglect; improper installation; improper operation; improper maintenance, repair, or alteration; accidents; or unusual deterioration or degradation of the equipment or parts thereof due to physical environment or due to electrical or electromagnetic noise environment.

This warranty is in lieu of all other warranties, expressed, implied, or statutory, including warranties of merchantability or fitness for a specific purpose.