

ICM-EBB-IO-54RE-P

Enhanced Baby Bear I/O Expander with Relays

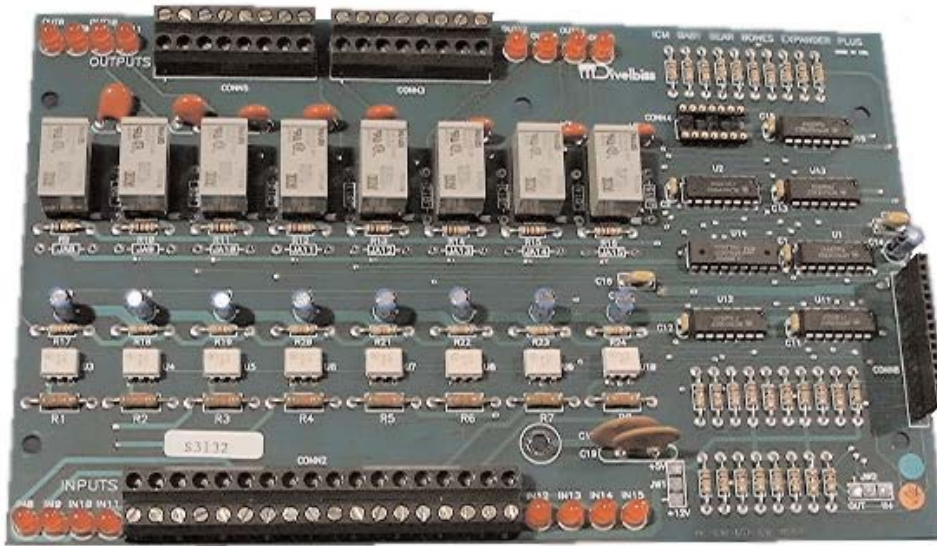

Technical Datasheet for the ICM-EBB-IO-54RE-P

Revision 0

Release Date 2/13/2006

Divebiss Corporation
9778 Mt. Gilead Rd.
Fredericktown, Ohio 43019

Phone: 1-800-245-2327
Fax: 740-694-9035
www.divebiss.com

All Specifications Subject to Change without Notice



DATA SHEET

Table of Contents

Title	Pages
Description.....	3
Features.....	3
Connections.....	3
Programming.....	4
Jumper Settings.....	4
Digital Inputs.....	5
Digital Outputs.....	6
Mounting.....	7
Specifications.....	8

WARNING!

The ICM-EBB-IO-54RE-P, as with other solid state devices, must not be used alone in applications which would be hazardous to personnel in the event of failure of this device. Precautions must be taken by the user to provide mechanical and/or electrical safeguards external to this device. This device is **NOT APPROVED** for domestic or human medical use.



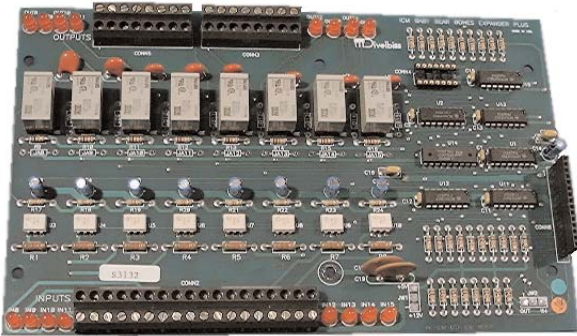

The ICM-EBB-IO-54RE-P is a stackable I/O expander for the Enhanced Baby Bear Programmable Logic Controller. This expander allows you to expand the Enhanced Baby Bear by adding an additional 8 DC inputs and 8 Relay outputs.

Features

- 8 Digital Inputs :** DC Voltage (Can use +5VDC or +12VDC provided on-board or external source up to 24VDC).
- 8 Relay Outputs :** ICM-RE-04 Factory Installed (rated 5A @ 30VDC / 250VAC Resistive)
- LED Status Indicators for I/O**
- Pull Apart Terminal Blocks**
- Mounts Directly to Enhanced Baby Bear**

Connections

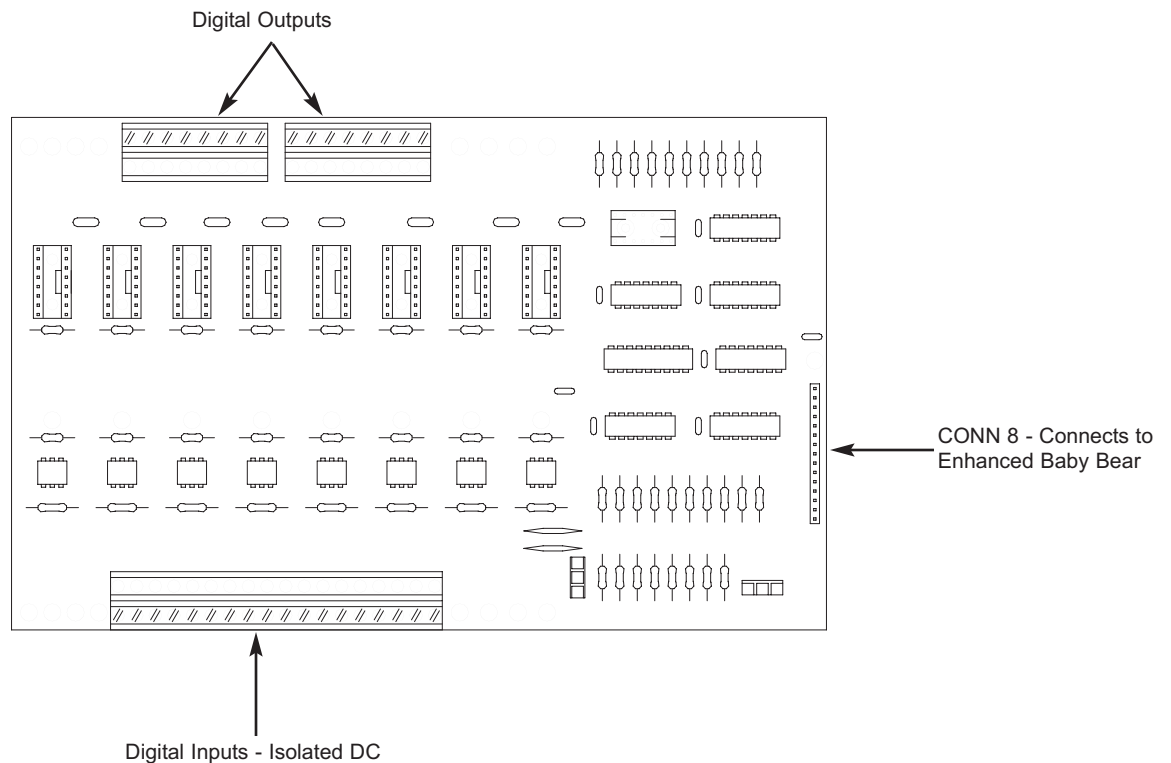

Programming

The ICM-EBB-IO-54RE-P receives its programming instructions from the Enhanced Baby Bear Programmable Controller.

Jumper Settings

The ICM-EBB-IO-54RE-P provides on-board "options" jumpers. These are factory set for the most commonly required configuration.

- JW1:** Factory defaults to provide +12VDC to the +V terminals on the input terminal block. If you require 5VDC, then this jumper must be cut and reconnected. See below for details. If you would like to use the +V terminals for an externally supplied voltage source, then this jumper would need cut but not reconnected.
- JW2:** Factory default to provided interface with the Enhanced Baby Bear. This jumper should be set from the "center pad" to the "IN pad" for use with the Enhanced Baby Bear. With the jumper in this configuration, the ICM-EBB-IO-54RE-P is no longer compatible with the original Baby Bear Bones. To use this board with the original Baby Bear Bones, the "center pad" would need to be connected to the "OUT pad" (and not connected to the "IN pad"). See below page for details.

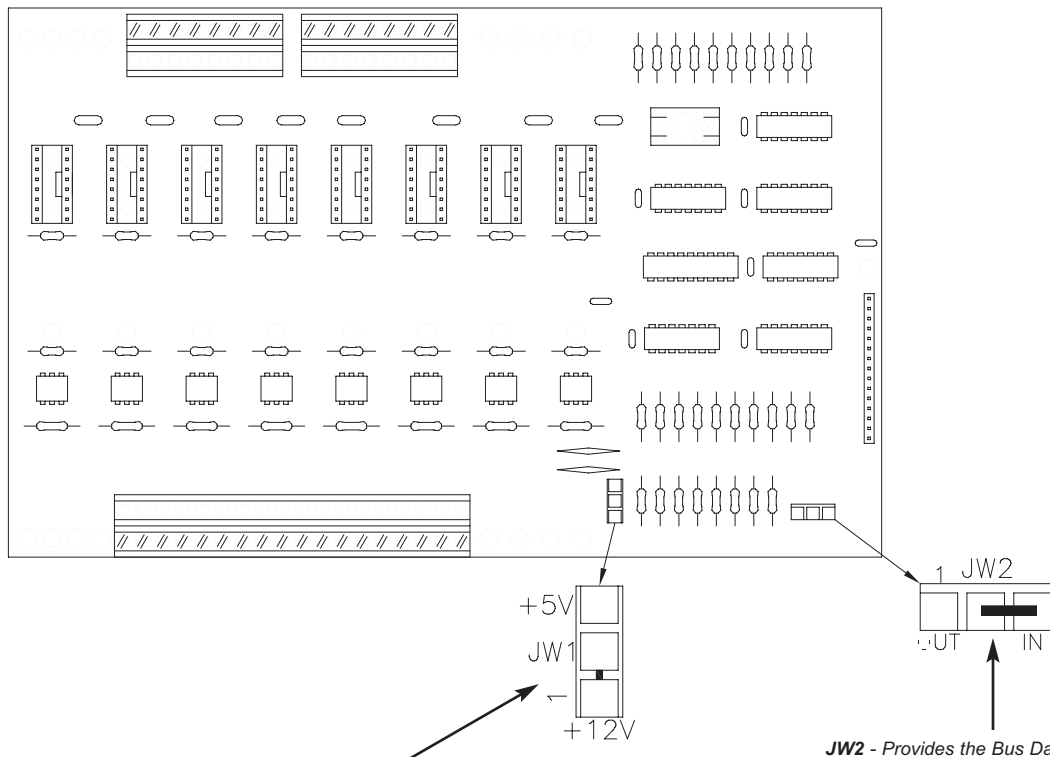

JW1 - Provides the voltage present on the input terminal block +V terminal.

Factory default from "Center" to "+12" to supply +12V to the +V input terminal block

To set for 5V, cut the jumper shown and then solder a jumper from "Center" to "+5V".

To use an external supply, cut the jumper shown.

JW2 - Provides the Bus Data Source

Factory default from "Center" to "IN" for Enhanced Baby Bear operation.

Digital Inputs

Each ICM-EBB -IO-54RE-P comes standard with eight (8) DC voltage digital inputs. All digital inputs are optically isolated to provide immunity from noise and interference. These inputs are polarity sensitive.

The +V terminal is used to provide +12VDC (see jumper settings) to the input devices if required.

EZ LADDER input assignments for the ICM-EBB-IO-54RE-P are DI1.08 (Input 0) to DI1.15 (Input 7).

	Source Voltage	Resistance		Current		Response Time	
		Min	Max	Min	Max	Min	Max
On-board	5VDC	1.5K	3.5K	.3mA	.8mA	2mS	15mS
On-board	12VDC	10K	15K	.3mA	.8mA	2mS	15mS
External up to	24VDC	25K	35K	.3mA	.8mA	2mS	2mS

Input Connections

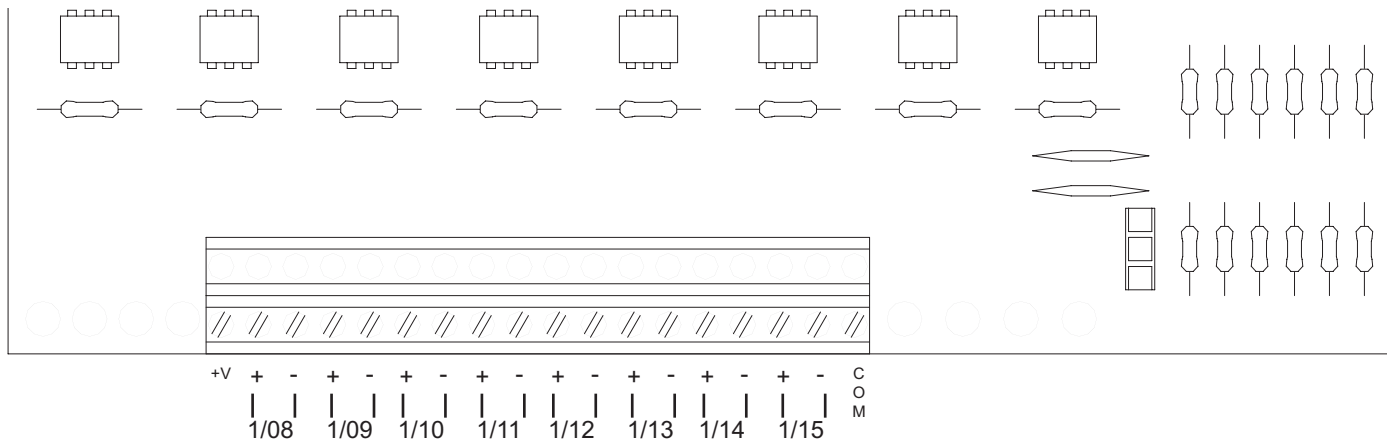

Typical Input Wiring Diagrams

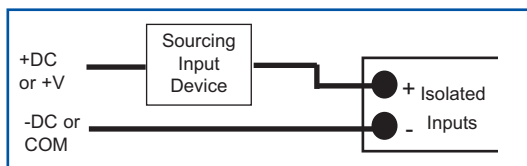

Typical Sinking Input Circuit

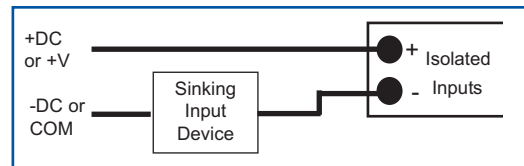

Typical Sourcing Input Circuit

Digital Outputs

Each ICM-EBB IO-54RE-P comes standard with eight ICM-RE-04 relays factory installed .

EZ LADDER output assignments for the ICM-EBB-IO-54RE-P are DO1.08 to DO1.15.

Output Connections

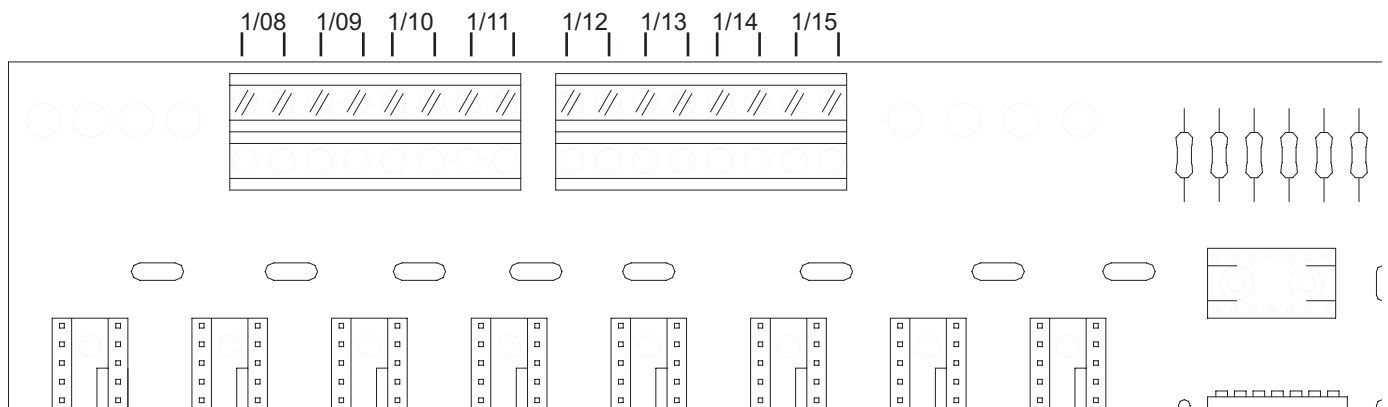

Typical Output Wiring Diagrams

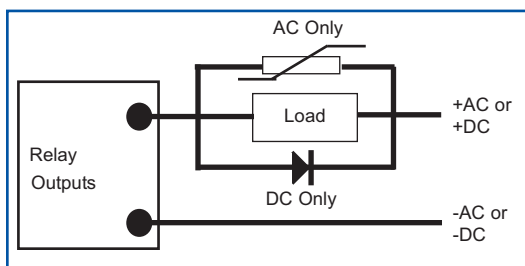

Typical Output Circuit Connection

It is highly recommended that all output drivers be protected by connecting varistors to AC loads and snubbers to DC loads. These are depicted in the typical wiring diagram. These protection devices must be sized to service the loads that are connected.

Note: The addition of snubbers may increase drop out time of DC devices from 200% to 500%. AC loads are not usually effected.

Mounting

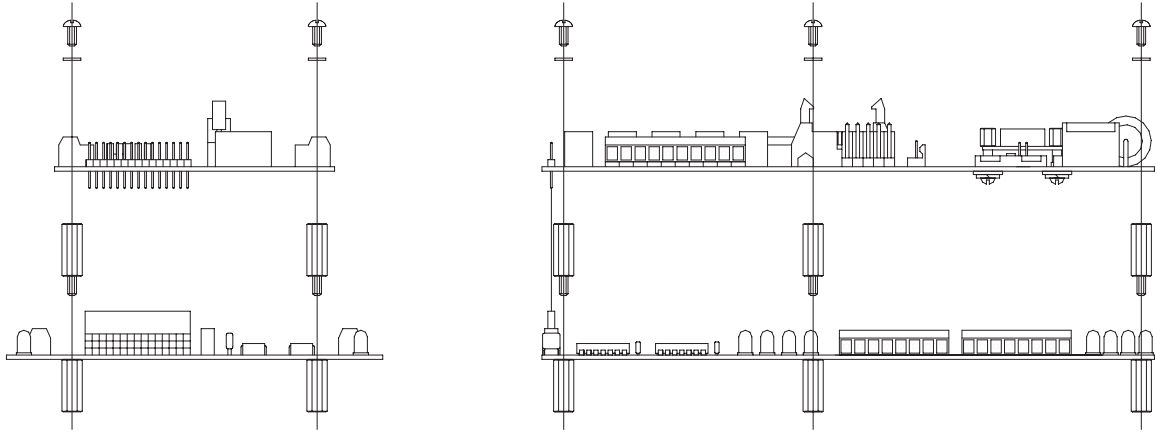

ICM-EBB-IO-54RE-P Stackable Mounting

Dimensions

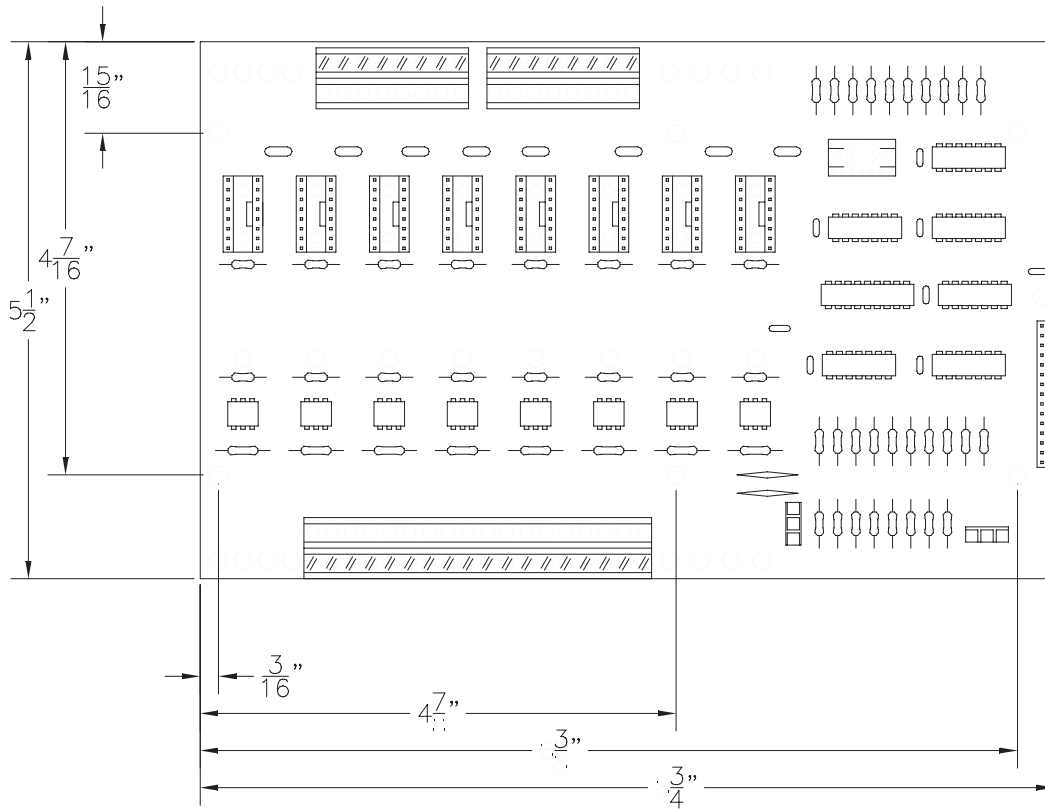

Specifications

Input Power	12 VDC / 5VDC Supplied from Enhanced Baby Bear
Operating Temperature	0 - 60 degrees C
Digital Inputs	8
Type	Optically Isolated, Solid State
Polarity Sensitive	Yes
Input Voltage	5-24VDC (Supplied on-board or optional external supply)
LED Indicators	Yes
Digital Outputs	8
Type	Relay, 5A @ 30VDC / 250VAC Resistive
Input LED Indicators	Yes
Mounting	Stand-off Hardware
Connections	Quick Disconnect Terminal Strips and Connectors Standard
Dimensions	5.375" Wide x 8.75" Length x .75" Tall

