

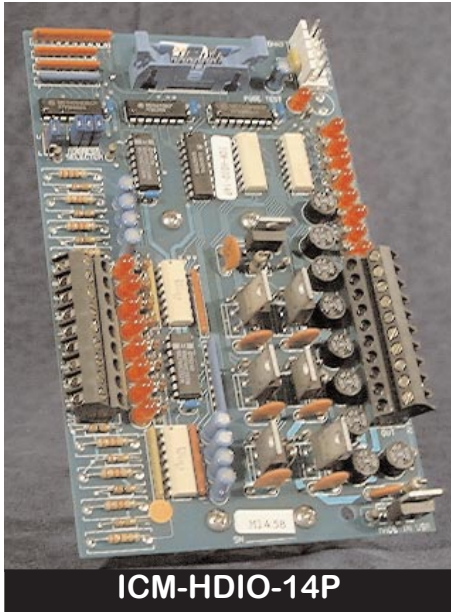

Electronic Solutions for the 21st Century

# ICM-HDIO-14P

## High Denisty I/O Expander - 8 In / 8 Out AC Commoned



ICM-HDIO-14P

### PRODUCT DESCRIPTION:

The ICM-HDIO-14P is designed for direct connection with any of the Divebiss *Bear Bones*, *High Density Bear Bones*, *Boss Bear*, *Boss32*, *Universal Control Panel (UCP)* and *Universal Machine Controller (UMC)* product families.

### PRODUCT FEATURES:

- Quickly Connects using ICM-HDCA Series Cables
- Optically Isolated I/O points
- Reverse polarity protection
- Small size and light weight
- Mounts on industry standard DIN rail type NS31 or NS35
- Addressable via programming jumpers
- Detachable Input / Output blocks
- Polarized and locking data and power bus connections
- LED monitoring of I/O status
- Engineered to meet NEMA part ICS 3-304
- AC Commoned Inputs & Outputs
- Fused Outputs with Spare Fuse & Fuse Tester

Data Sheet

### Table of Contents

Input Specifications.....	2
Typical Input Connections & Circuit Diagrams.....	2
Output Specifications.....	3
Typical Output Connections & Circuit Diagrams.....	3
Addressing I/O Points.....	4
Power Consumption.....	4
Data Connections.....	4
Mounting & Dimensions.....	4
Connectivity Diagrams.....	5
Cabling.....	5

### ----WARNING----

The ICM-HDIO-14P, as with other solid state control devices, must not be used in applications which would be hazardous to personnel in the event of failure of the controller. Precautions must be taken to provide mechanical and/or electrical safeguards external to the controller. This device is **NOT APPROVED** for domestic or human medical use.





## INPUT SPECIFICATIONS:

# Channels:	8
Input Voltage:	24 VAC
Turn on Level:	12VAC @ 5mAAC Minimum, 60 Hz
Turn off Level:	9VAC @ 3.7mAAC Maximum, 60 Hz
Turn on Time:	50mS Nominal @ 24VAC, 60 Hz
Turn off Time:	50mS Nominal @ 24VAC, 60 Hz
Isolation (Input to Logic Level):	3KV Minimum for 1 Second
Isolation (Interchannel):	3KV Minimum for 1 Second
Input Impedance:	2.4KOhm Nominal
Input Types:	Sink or Source
Optical Isolation:	Yes
LED Status Indicators:	Yes

## TYPICAL INPUT CIRCUIT DIAGRAMS

Typical ICM-HDIO-14P Input Circuit

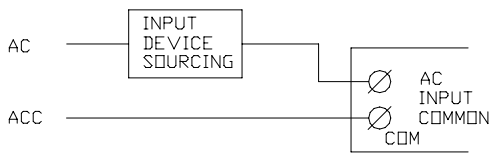
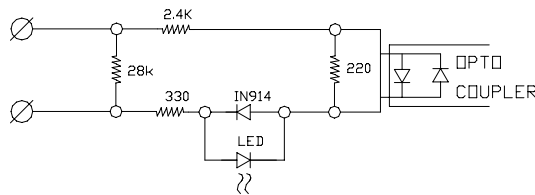

Sinking Input Circuit

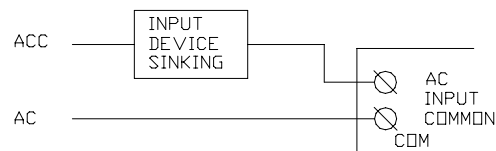

Sourcing Input Circuit



**OUTPUT SPECIFICATIONS:**

<b># Channels:</b>	8
<b>Nominal Source Voltage:</b>	10-120VAC
<b>Max Source Voltage:</b>	130 VAC
<b>“On” State Voltage Drop:</b>	2VAC Maximum @ 1 Amp
<b>Load Current:</b>	
Minimum:	50mAAC *
Maximum:	1 Amp*
<b>Turn On Time:</b>	1 Cycle Max.
<b>Turn Off Time:</b>	1 Cycle Max.
<b>Surge Current:</b>	10 Amp RMS Maximum for 2 Cycles*
<b>Isolation (Output to Logic Level):</b>	3KV Minimum for 1 Second
<b>Isolation (Interchannel):</b>	3KV Minimum for 1 Second
<b>Output Types:</b>	Sink or Source **
<b>Optical Isolation:</b>	Yes
<b>LED Status Indicators:</b>	Yes
<b>Fused:</b>	Yes
<b>“Off” State Leakage Current:</b>	1mAAC Max. @ 120VAC*

\* @ 0-55 Degrees C.

\*\* Sinking configuration is functional but not recommended for safety reasons. A Ground fault may cause load activations.

**TYPICAL OUTPUT CIRCUIT DIAGRAMS**

Typical ICM-HDIO-14P Output Circuit

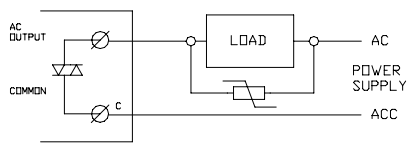
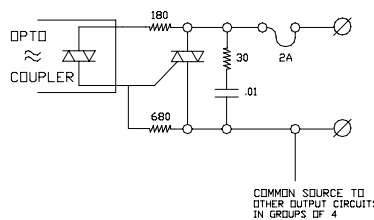

Sinking Output Circuit

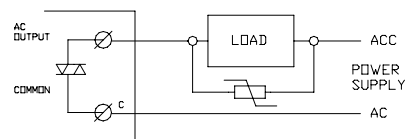

Sourcing Output Circuit



### Addressing I/O Points

The I/O is addressed into “pages”. Each “page” represents 16 inputs and 16 outputs. The HDIO-14P addresses a “half page”. It may be addressed to any page 0 through 7. Limitations apply when connected to a *Bear Bones*, *Baby Bear Bones* or *High Density Bear Bones* CPU. When connected to these CPUs, the HDIO may **NOT** be addressed on “Page 1”. “Page” selection is done via programming shunts “Address Selector(s) 1,2,4,8”. See page selection to the right for more details. *\*Note: Some models may only use selectors 1,2,4. Page 6 cannot be address when HDIO is used with PIC-AB-01.*

Card Page Address	Card Paging Shunts (Address Selector) 8 4 2 1	U/L Selector		DIN/ DOUT 8 I/O Cards	DIN/ DOUT 16 I/O Cards	Card Page Address	Card Paging Shunts (Address Selector) 8 4 2 1	U/L Selector		DIN/ DOUT 8 I/O Cards	DIN/ DOUT 16 I/O Cards
		Lower	Upper					Lower	Upper		
0	■ ■ ■ ■	U	L	0-7 8-15	0-15	8	○ ○ ■ ■	U	L	128-135 136-143	128-143
1	■ ■ ■ ■ ○	U	L	16-23 24-31	16-31	9	○ ○ ■ ■ ○	U	L	144-151 152-159	144-159
2	■ ■ ○ ■ ■	U	L	32-39 40-47	32-47	10	○ ○ ■ ■ ○	U	L	160-167 168-175	160-175
3	■ ■ ■ ○ ○	U	L	48-55 56-63	48-63	11	○ ○ ■ ■ ○	U	L	176-183 184-191	176-191
4	■ ○ ○ ■ ■	U	L	64-71 72-79	64-79	12	○ ○ ○ ■ ■	U	L	192-199 200-207	192-207
5	■ ○ ■ ○ ○	U	L	80-87 88-95	80-95	13	○ ○ ○ ■ ■	U	L	208-215 216-223	208-223
6	■ ○ ○ ○ ■	U	L	96-103 104-111	96-111	14	○ ○ ○ ○ ■	U	L	224-231 232-239	224-239
7	■ ○ ○ ○ ○	U	L	112-119 120-127	112-127	15	○ ○ ○ ○ ○	U	L	240-247 248-255	240-255

### Power Consumption

<b>Power Input Standby:</b>	+5VDC @ 2mA Maximum
<b>Power Input Origin:</b>	Controller/Aux Powersupply via Cable 3
<b>I/O Point Power Consumption:</b>	
Activated Inputs:	1.7mA each input point (additional)
Activated Outputs:	8mA each output point (additional)

### DATA CONNECTIONS

The data is received from the controller via a ribbon cable connected to Conn6. The controller provides all the addressing, data and selection signals necessary for complete operation.

### MOUNTING & DIMENSIONS

<b>Mounting Type:</b>	Industry Standard DIN Rail NS 31 or NS 35
<b>Dimensions:</b>	
Width:	4.00 Inches
Length:	6.65 Inches
Depth:	1.7 Inches (including din rail mounting feet)



**CONNECTIVITY DIAGRAMS**

For additional Addressing, See Chart on Page 4.

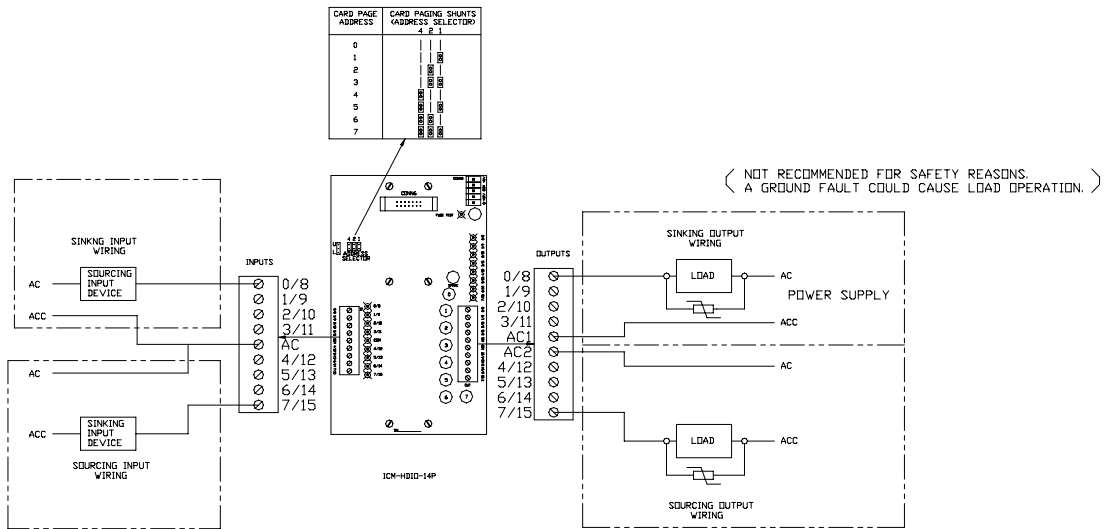

Maximum Recommended wire size is 14 AWG.

**CABLING**

The ICM-HDIO-14P connects to any of the Divebiss controllers using standard cable sets. See below for proper cable. Custom Cabling is also available.

**Connect to Boss32, UCP, UMC and HDCPU.**

ICM-HDCA-01	Connects 1 Expander (9")
ICM-HDCA-02	Connects 2 Expander (18")
ICM-HDCA-03	Connects 3 Expander (27")
ICM-HDCA-04	Connects 4 Expander (36")
ICM-HDCA-05	Connects 5 Expander (45")
ICM-HDCA-06	Connects 6 Expander (54")

**Connect to Boss Bear, Bear Bones, and Baby Bear Bones.**

ICM-HDCA-11	Connects 1 Expander (9")
ICM-HDCA-12	Connects 2 Expander (18")
ICM-HDCA-13	Connects 3 Expander (27")
ICM-HDCA-14	Connects 4 Expander (36")
ICM-HDCA-15	Connects 5 Expander (45")
ICM-HDCA-16	Connects 6 Expander (54")

Data Sheet