



Electronic Solutions for the 21st Century

ICM-HDIO-08P

High Denisty I/O Expander - 8 In / 8 Out DC Commoned



ICM-HDIO-08P

PRODUCT DESCRIPTION:

The ICM-HDIO-08P is designed for direct connection with any of the Divebiss *Bear Bones*, *High Density Bear Bones*, *Boss Bear*, *Boss32*, *Universal Control Panel (UCP)* and *Universal Machine Controller (UMC)* product families.

PRODUCT FEATURES:

- Quickly Connects using ICM-HDCA Series Cables
- Optically Isolated I/O points
- Reverse polarity protection
- Small size and light weight
- Mounts on industry standard DIN rail type NS31 or NS35
- Addressable via programming jumpers
- Detachable Input / Output blocks
- Polarized and locking data and power bus connections
- LED monitoring of I/O status
- Engineered to meet NEMA part ICS 3-304
- DC Commoned Inputs & Outputs
- Fused Outputs with Spare Fuse & Fuse Tester

Data Sheet



Proudly Made in the USA

Table of Contents

Input Specifications.....	2
Typical Input Connections & Circuit Diagrams.....	2
Output Specifications.....	3
Typical Output Connections & Circuit Diagrams.....	3
Addressing I/O Points.....	4
Power Consumption.....	4
Data Connections.....	4
Mounting & Dimensions.....	4
Connectivity Diagrams.....	5
Cabling.....	5

----WARNING----

The ICM-HDIO-08P, as with other solid state control devices, must not be used in applications which would be hazardous to personnel in the event of failure of the controller. Precautions must be taken to provide mechanical and/or electrical safeguards external to the controller. This device is **NOT APPROVED** for domestic or human medical use.



INPUT SPECIFICATIONS:

# Channels:	8
Input Voltage:	10-32 VDC
Turn on Level:	8VDC @ 2.3mADC Minimum
Turn off Level:	2.5VDC @ 0.05mADC Maximum
Turn on Time:	
with debounce:	30mSec Nominal @ 24VDC
without debounce:	2µSec Nominal @ 24VDC
Turn off Time:	
with debounce:	30mSec Nominal @ 24VDC
without debounce:	30µSec Nominal @ 24VDC
Isolation (Input to Logic Level):	3.6KV Minimum for 1 Second
Isolation (Interchannel):	3KV Minimum for 1 Second
Static Input Resistance:	2KOhm Nominal
Input Types:	Sink
Optical Isolation:	Yes
LED Status Indicators:	Yes

TYPICAL INPUT CIRCUIT DIAGRAMS

Typical ICM-HDIO-08P Input Circuit

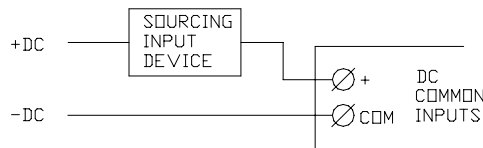
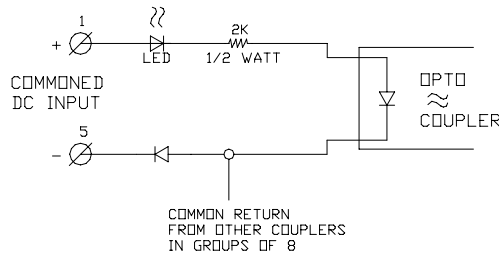

Sinking Input Circuit



OUTPUT SPECIFICATIONS:

# Channels:	8
Nominal Source Voltage:	24 VDC
Max Source Voltage:	30 VDC
“On” State Voltage Drop:	2.4VDC Maximum @ 1 Amp
Load Current:	
Minimum:	.5mADC*
Maximum:	1 Amp*
Turn On Time:	10 μ Sec Maximum
Turn Off Time:	1mSec Maximum
Surge Current:	2 Amp Maximum for 1 Second*
Isolation (Output to Logic Level):	3.6KV Minimum for 1 Second
Isolation (Interchannel):	3KV Minimum for 1 Second
Output Types:	Sink
Optical Isolation:	Yes
LED Status Indicators:	Yes
Fused:	Yes
“Off” State Leakage Current:	100 μ ADC Max. @ 30 VDC*

* @ 0-55 Degrees C.

TYPICAL OUTPUT CIRCUIT DIAGRAMS

Typical ICM-HDIO-08P Output Circuit

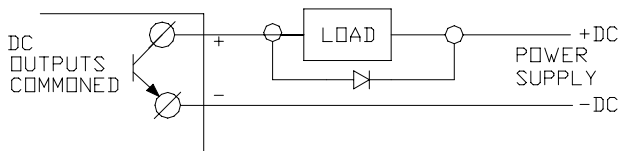
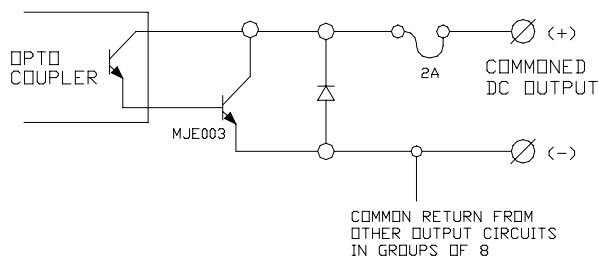

Sinking Output Circuit



Addressing I/O Points

The I/O is addressed into “pages”. Each “page” represents 16 inputs and 16 outputs. The HDIO-08P addresses a “half page”. It may be addressed to any page 0 through 7. Limitations apply when connected to a *Bear Bones*, *Baby Bear Bones* or *High Density Bear Bones* CPU. When connected to these CPUs, the HDIO may **NOT** be addressed on “Page 1”. “Page” selection is done via programming shunts “Address Selector(s) 1,2,4,8”. See page selection to the right for more details. **Note: Some models may only use selectors 1,2,4. Page 6 cannot be address when HDIO is used with PIC-AB-01.*

Card Page Address	Card Paging Shunts (Address Selector) 8 4 2 1	U/L Selector		DIN/ DOUT 8 I/O Cards	DIN/ DOUT 16 I/O Cards	Card Page Address	Card Paging Shunts (Address Selector) 8 4 2 1	U/L Selector		DIN/ DOUT 8 I/O Cards	DIN/ DOUT 16 I/O Cards
		Lower	Upper					Lower	Upper		
0	■ ■ ■ ■	U	L	0-7 8-15	0-15	8	○ ○ ■ ■	U	L	128-135 136-143	128-143
1	■ ■ ■ ○	U	L	16-23 24-31	16-31	9	○ ○ ■ ■	U	L	144-151 152-159	144-159
2	■ ■ ○ ■	U	L	32-39 40-47	32-47	10	○ ○ ■ ■	U	L	160-167 168-175	160-175
3	■ ■ ○ ○	U	L	48-55 56-63	48-63	11	○ ○ ■ ■	U	L	176-183 184-191	176-191
4	■ ○ ○ ■	U	L	64-71 72-79	64-79	12	○ ○ ■ ■	U	L	192-199 200-207	192-207
5	■ ○ ○ ○	U	L	80-87 88-95	80-95	13	○ ○ ■ ■	U	L	208-215 216-223	208-223
6	■ ○ ○ ○	U	L	96-103 104-111	96-111	14	○ ○ ■ ■	U	L	224-231 232-239	224-239
7	■ ○ ○ ○	U	L	112-119 120-127	112-127	15	○ ○ ■ ■	U	L	240-247 248-255	240-255

Power Consumption

Power Input Standby:	+5VDC @ 2mA Maximum
Power Input Origin:	Controller/Aux Powersupply via Cable 3
I/O Point Power Consumption:	
Activated Inputs:	1.7mA each input point (additional)
Activated Outputs:	8mA each output point (additional)

DATA CONNECTIONS

The data is received from the controller via a ribbon cable connected to Conn6. The controller provides all the addressing, data and selection signals necessary for complete operation.

MOUNTING & DIMENSIONS

Mounting Type:	Industry Standard DIN Rail NS 31 or NS 35
Dimensions:	
Width:	4.25 Inches
Length:	4.225 Inches
Depth:	1.7 Inches (including din rail mounting feet)



CONNECTIVITY DIAGRAMS

For additional Addressing, See Chart on Page 4.

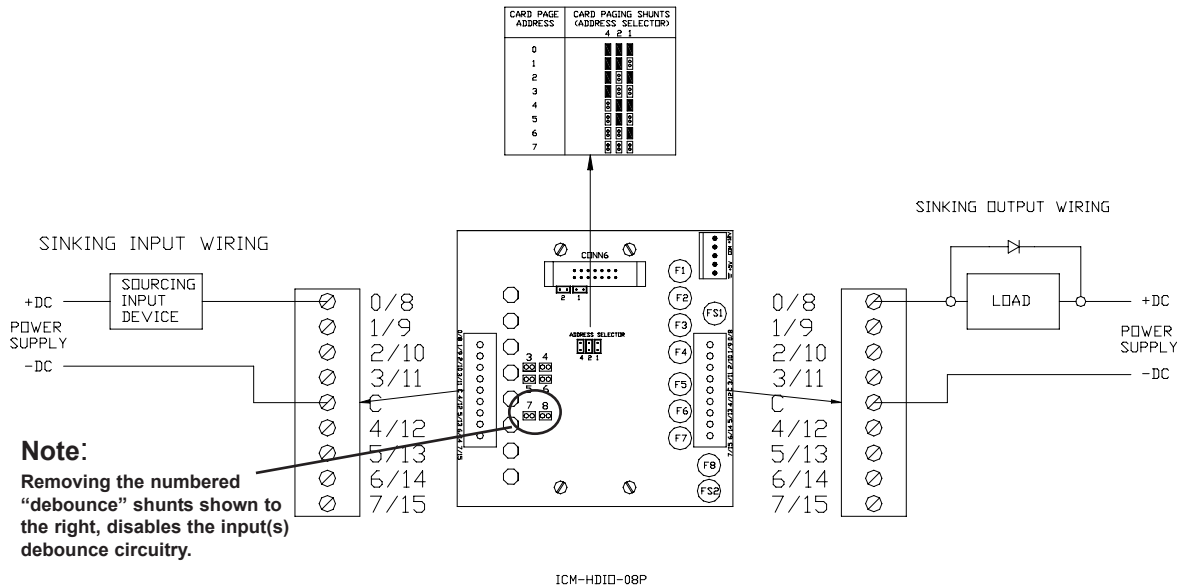

Maximum Recommended wire size is 14 AWG.

CABLING

The ICM-HDIO-08P connects to any of the Divebiss controllers using standard cable sets. See below for proper cable. Custom Cabling is also available.

Connect to Boss32, UCP, UMC and HDCPU.

ICM-HDCA-01	Connects 1 Expander (9")
ICM-HDCA-02	Connects 2 Expander (18")
ICM-HDCA-03	Connects 3 Expander (27")
ICM-HDCA-04	Connects 4 Expander (36")
ICM-HDCA-05	Connects 5 Expander (45")
ICM-HDCA-06	Connects 6 Expander (54")

Connect to Boss Bear, Bear Bones, and Baby Bear Bones.

ICM-HDCA-11	Connects 1 Expander (9")
ICM-HDCA-12	Connects 2 Expander (18")
ICM-HDCA-13	Connects 3 Expander (27")
ICM-HDCA-14	Connects 4 Expander (36")
ICM-HDCA-15	Connects 5 Expander (45")
ICM-HDCA-16	Connects 6 Expander (54")