

- ▶ J1939 Connectivity
- ▶ Sealed From Environment
- ▶ Mounts Directly to Machine
- ▶ -40 to 80°C Operating Temperature
- ▶ Quick Disconnect Field Connections
- ▶ Programs with EZ Ladder® Software
- ▶ High Current Outputs with PWM
- ▶ Analog Inputs
- ▶ High Speed Counting
- ▶ Visual Status Indicator (Watchdog LED)
- ▶ Output Monitoring for Overloaded / Open Circuit



HEC-1000 Harsh Environment Controller allows for programmable intelligence under less than ideal conditions. Features include a sealed, water-tight enclosure, analog and digital I/O, real-time clock, high speed counting, and CAN network communication with J1939. Based on patented* PLC on a Chip® technology, the controller is easy to apply and program using the EZ Ladder® PC based software. The HEC-1000 is suitable for direct mounting on machines and is an ideal choice for mobile applications.

Typical applications include:

- ▶ Mobile Equipment
- ▶ Material Handling
- ▶ Off Road Equipment
- ▶ Food Processing Equipment
- ▶ Remote Locations Monitoring & Control
- ▶ Engine Driven Pumps, Compressors and Generators

Specifications:

Memory: 256K Flash, 12K RAM
Serial Ports: 1 Programming Port (Max baud 57.6K), 1 Optional (Choice of RS232, RS422, RS485)
Networking: OptiCAN, J1939 Read Only support, Modbus Slave
Digital I/O: 6 Inputs and 6 Outputs (selectable PWM / digital)
Inputs: rated 8 to 32VDC
Outputs: Sourcing rated @ 3A Maximum (resistive), PWM frequency programmable 1.436 Hz to 1KHz, PWM Range: 5 - 95%, Over-current protected, Output Voltage equal to Input Voltage
Real Time Clock: Time of Day, Day, Month, Year, and Day of Week
Counters: 2 Channels, Count Up, 40KHz Max. (using Digital Inputs 0 and 1)
Analog Inputs: 2 Channels, 10-bit Resolution, rated 0 to 20mA DC
Input Voltage: 8 to 32VDC
Operating Temperature: -40 to 80° C (-40 to 176° F)
Program Language: Ladder Logic with Function Block using Divebiss EZ Ladder PC based software
Mounting: Panel Mount using screws
Type: NEMA 4X, Sealed Plastic Housing

NOTE: A User's Manual is available for download from our website: www.divebiss.com

* Patent 7,299,099

HEC

Harsh Environment Controller

Hardware Selection Guide

Model #	Description
HEC-1000	Harsh Environment Controller with J1939 communications, 6 DC inputs (2 configurable for High-speed Counter input), 6 DC/PWM outputs, 2 Analog inputs, and a CAN Network port
HEC-1001	Additional COM port configured as RS-232
HEC-1002	Additional COM port configured as RS-422
HEC-1003	Additional COM port configured as RS-485

Optional Hardware Add-ons

Model #	Description
HEC-10	"A" Key Connector Kit
Includes:	1 DTM06-12SA 12 1062-20-0122 (16-20AWG socket pins) 1 Wedge Lock
HEC-20	"B" Key Connector Kit
Includes:	1 DTM06-12SB 12 1062-20-0122 (16-20AWG socket pins) 1 Wedge Lock
HEC-CRMPTL	Crimp Tool (DTT-20-0)
HEC-100	"A" Key Cable Assembly with 6 ft flying leads
HEC-110	"B" Key Cable Assembly with 6 ft flying leads
HEC-140	Shielded "A" Key Cable Assembly with 6 ft flying leads
HEC-150	Shielded "B" Key Cable Assembly with 6 ft flying leads
HEC-900	Programming Breakout Cable in-line Deutsch connector for serial connection
HEC-910	Programming Breakout Cable 9-pin D-sub connector for serial connection
HEC-920	Programming Cable (mates with HEC-900) 9-pin D-sub connector to Deutsch
ICM-CA-34	RS232 Null Modem Programming Cable

Dimensions

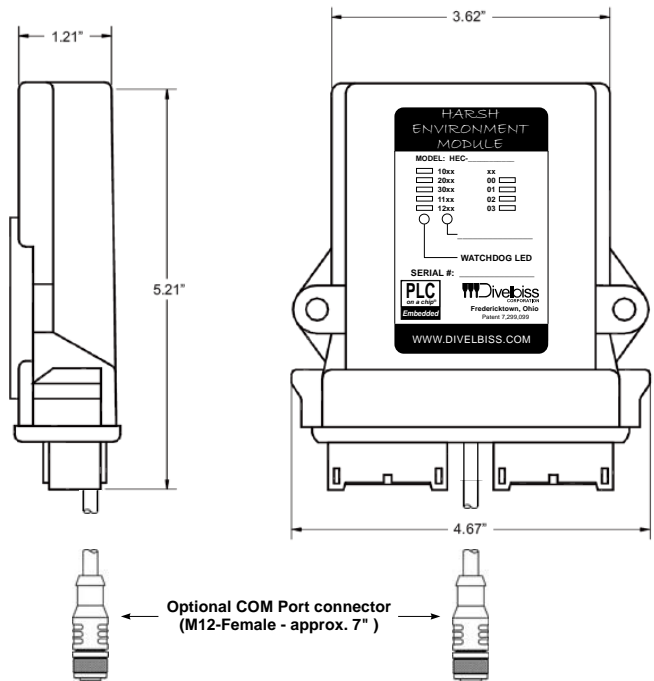

Programming Software

Description	Divebiss Part #
EZ Ladder® Development Platform	ICM-EZLDCD-01
Includes: EZ Ladder Development Platform CD	

Programming the Controller

The Harsh Environment Controller PLCs program in Ladder Diagram using the Divebiss EZ Ladder®, a Ladder Diagram Development Platform. EZ Ladder software parallels the IEC-61131 standard and provides an easy to use interface.

After a ladder diagram program is developed, it can be downloaded to the HEC controller via the serial port. The program is stored on non-volatile FLASH memory and is automatically executed on power up. Once the download is complete, the HEC is successfully programmed and begins executing the program.

Refer to the EZ Ladder User's Manual for more detail on creating ladder diagram programs, connecting to targets and downloading the program to targets. The manual can be downloaded from our website: <http://www.divebiss.com>

NOTE: Specifications are subject to change without notice.

2006006.4